



EN

Power source

Titan XQ 400 AC puls D

099-005607-EW501

Observe additional system documents!

30.08.2024

**Register now
and benefit!
Jetzt Registrieren
und Profitieren!**

www.ewm-group.com



General instructions

WARNING



Read the operating instructions!

The operating instructions provide an introduction to the safe use of the products.

- Read and observe the operating instructions for all system components, especially the safety instructions and warning notices!
- Observe the accident prevention regulations and any regional regulations!
- The operating instructions must be kept at the location where the machine is operated.
- Safety and warning labels on the machine indicate any possible risks. Keep these labels clean and legible at all times.
- The machine has been constructed to state-of-the-art standards in line with any applicable regulations and industrial standards. Only trained personnel may operate, service and repair the machine.
- Technical changes due to further development in machine technology may lead to a differing welding behaviour.

In the event of queries on installation, commissioning, operation or special conditions at the installation site, or on usage, please contact your sales partner or our customer service department on +49 2680 181-0.

A list of authorised sales partners can be found at www.ewm-group.com/en/specialist-dealers.

Liability relating to the operation of this equipment is restricted solely to the function of the equipment. No other form of liability, regardless of type, shall be accepted. This exclusion of liability shall be deemed accepted by the user on commissioning the equipment.

The manufacturer is unable to monitor whether or not these instructions or the conditions and methods are observed during installation, operation, usage and maintenance of the equipment.

An incorrectly performed installation can result in material damage and injure persons as a result. For this reason, we do not accept any responsibility or liability for losses, damages or costs arising from incorrect installation, improper operation or incorrect usage and maintenance or any actions connected to this in any way.

© EWM GmbH

Dr. Günter-Henle-Strasse 8

56271 Mündersbach Germany

Tel.: +49 2680 181-0, Fax: -244

Email: info@ewm-group.com

www.ewm-group.com

The copyright to this document remains the property of the manufacturer.

Copying, including extracts, only permitted with written approval.

The content of this document has been prepared and reviewed with all reasonable care. The information provided is subject to change; errors excepted.

Data security

The user is responsible for backing up data of all changes from the factory setting. The user is liable for erased personal settings. The manufacturer does not assume any liability for this.

1 Contents

1	Contents	3
2	For your safety	5
2.1	Notes on using these operating instructions	5
2.2	Explanation of icons	6
2.3	Safety instructions.....	7
2.4	Transport and installation	10
3	Intended use	12
3.1	Use and operation solely with the following machines	12
3.2	Applications.....	12
3.3	Documents which also apply	13
3.3.1	Warranty	13
3.3.2	Declaration of Conformity	13
3.3.3	Welding in environments with increased electrical hazards	13
3.3.4	Service documents (spare parts and circuit diagrams).....	13
3.3.5	Calibration/Validation.....	13
3.3.6	Part of the complete documentation.....	14
4	Machine description – quick overview	15
4.1	Machine configuration.....	15
4.2	Front view / side view from the right	16
4.3	Rear view / side view from left	18
5	Design and function	20
5.1	Transport and installation	20
5.1.1	Lifting by crane	20
5.1.1.1	Craning principle	20
5.1.2	Ambient conditions	21
5.1.3	Machine cooling.....	21
5.1.4	Workpiece lead, general.....	21
5.1.5	Welding torch cooling system.....	22
5.1.5.1	Functional characteristics	22
5.1.5.2	Permitted torch coolant	22
5.1.5.3	Maximal hose package length	22
5.1.5.4	Adding coolant	23
5.1.6	Notes on the installation of welding current leads	24
5.1.7	Stray welding currents	25
5.1.8	Shielding gas supply (shielding gas cylinder for welding machine)	25
5.1.8.1	Pressure regulator connection	26
5.1.9	Mains connection.....	27
5.1.9.1	Mains configuration	27
5.1.10	Switching on and system diagnosis	27
5.1.10.1	LED status bar - display of operating status	28
5.1.11	Protective flap, welding machine control	28
5.2	MIG/MAG welding.....	29
5.2.1	Connecting the intermediate hose package to the power source	29
5.2.1.1	Intermediate hose package strain relief	30
5.2.1.2	Possible attachment points	30
5.2.1.3	Locking the strain relief	31
5.2.2	Connection for workpiece lead	31
5.2.3	Setting the shielding gas volume (gas test)/rinse hose package	32
5.2.4	Welding task selection.....	32
5.3	TIG welding.....	33
5.3.1	Connecting the intermediate hose package to the power source	33
5.3.2	Intermediate hose package strain relief	34
5.3.2.1	Possible attachment points	34
5.3.2.2	Locking the strain relief	34
5.3.3	Connection for workpiece lead	35
5.3.4	Welding task selection.....	35
5.4	MMA welding	36
5.4.1	Connecting the electrode holder and workpiece lead	36

5.4.2	Welding task selection	36
5.5	Remote control	36
5.6	Interfaces for automation	37
5.6.1	Automation interface	37
5.6.2	RINT X12 robot interface	38
5.6.3	BUSINT X11 industrial bus interface	38
5.7	PC interface	38
5.7.1	Connection	38
5.8	Component identification	38
5.9	Network connection	39
6	Maintenance, care and disposal	40
6.1	General	40
6.2	Explanation of icons	40
6.3	Maintenance schedule	40
6.3.1	Dirt filter	42
6.3.2	Coolant error	43
6.3.3	Heat exchanger (torch cooling)	45
6.3.4	Power source (inverter)	46
6.3.5	Annual test (inspection and testing during operation)	46
6.4	Disposing of equipment	47
7	Rectifying faults	48
7.1	Error messages (power source)	48
7.2	Warnings	55
7.3	Checklist for rectifying faults	56
7.4	Vent coolant circuit	58
7.5	Fixing the pump shaft (coolant circuit)	59
8	Technical data	60
8.1	Titan XQ 400 AC puls D	60
8.1.1	Dimensions and weights	60
8.1.2	Welding torch cooling system	60
8.1.3	Performance data	61
9	Accessories	62
9.1	System components	62
9.1.1	Wire feed unit	62
9.2	Welding torch cooling system	62
9.2.1	Coolant - type blueCool	62
9.3	7-pole remote control	62
9.4	Option for retrofitting	62
9.5	Option for conversion	63
9.6	Shielding gas supply (shielding gas cylinder for welding machine)	63
9.7	General accessories	63
9.8	Computer communication	63
9.9	Networking / Xnet	64
9.9.1	Connection cables	64
9.9.2	Component identification	64
10	Appendix	65
10.1	Average wire electrode usage	65
10.2	Average shielding gas usage	65
10.2.1	MIG/MAG welding	65
10.2.2	TIG welding	65
10.3	Searching for a dealer	66

2 For your safety

2.1 Notes on using these operating instructions

DANGER

Working or operating procedures which must be closely observed to prevent imminent serious and even fatal injuries.

- Safety notes include the "DANGER" keyword in the heading with a general warning symbol.
- The hazard is also highlighted using a symbol on the edge of the page.

WARNING

Working or operating procedures which must be closely observed to prevent serious and even fatal injuries.

- Safety notes include the "WARNING" keyword in the heading with a general warning symbol.
- The hazard is also highlighted using a symbol in the page margin.

CAUTION

Working or operating procedures which must be closely observed to prevent possible minor personal injury.

- The safety information includes the "CAUTION" keyword in its heading with a general warning symbol.
- The risk is explained using a symbol on the edge of the page.



Technical aspects which the user must observe to avoid material or equipment damage.

Instructions and lists detailing step-by-step actions for given situations can be recognised via bullet points, e.g.:

- Insert the welding current lead socket into the relevant socket and lock.

2.2 Explanation of icons

Symbol	Description	Symbol	Description
	Indicates technical aspects which the user must observe.		Activate and release / Tap / Tip
	Switch off machine		Release
	Switch on machine		Press and hold
	Incorrect / Invalid		Switch
	Correct / Valid		Turn
	Input		Numerical value – adjustable
	Navigation		Signal light lights up in green
	Output		Signal light flashes green
	Time representation (e.g.: wait 4 s / actuate)		Signal light lights up in red
	Interruption in the menu display (other setting options possible)		Signal light flashes red
	Tool not required/do not use		Signal light lights up in blue
	Tool required/use		Signal light flashes blue

2.3 Safety instructions

WARNING



Risk of accidents due to non-compliance with the safety instructions!
Non-compliance with the safety instructions can be fatal!

- Carefully read the safety instructions in this manual!
- Observe the accident prevention regulations and any regional regulations!
- Inform persons in the working area that they must comply with the regulations!



Risk of injury from electrical voltage!

Voltages can cause potentially fatal electric shocks and burns on contact. Even low voltages can cause a shock and lead to accidents.

- Never touch live components such as welding current sockets or stick, tungsten or wire electrodes!
- Always place torches and electrode holders on an insulated surface!
- Wear the full personal protective equipment (depending on the application)!
- The machine may only be opened by qualified personnel!
- The device must not be used to defrost pipes!



Hazard when interconnecting multiple power sources!

If a number of power sources are to be connected in parallel or in series, only a technical specialist may interconnect the sources as per standard IEC 60974-9:2010: Installation and use and German Accident Prevention Regulation BVG D1 (formerly VBG 15) or country-specific regulations.

Before commencing arc welding, a test must verify that the equipment cannot exceed the maximum permitted open circuit voltage.

- Only qualified personnel may connect the machine.
- When taking individual power sources out of operation, all mains and welding current leads must be safely disconnected from the welding system as a whole. (Hazard due to reverse polarity voltage!)
- Do not interconnect welding machines with pole reversing switch (PWS series) or machines for AC welding since a minor error in operation can cause the welding voltages to be combined, which is not permitted.



Risk of injury due to radiation or heat!

Arc radiation can lead to skin and eye injuries.

Contact with hot workpieces and sparks can lead to burns.

- Use hand shield or welding helmet with the appropriate safety level (depends on the application).
- Wear dry protective clothing (e.g. hand shield, gloves, etc.) in accordance with the applicable regulations of your country.
- Persons who are not directly involved should be protected with a welding curtain or suitable safety screen against radiation and the risk of blinding!

WARNING



Risk of injury due to improper clothing!

During arc welding, radiation, heat and voltage are sources of risk that cannot be avoided. The user has to be equipped with the complete personal protective equipment at all times. The protective equipment has to include:

- Respiratory protection against hazardous substances and mixtures (fumes and vapours); otherwise implement suitable measures such as extraction facilities.
- Welding helmet with proper protection against ionizing radiation (IR and UV radiation) and heat.
- Dry welding clothing (shoes, gloves and body protection) to protect against warm environments with conditions comparable to ambient temperatures of 100 °C or higher and arcing and work on live components.
- Hearing protection against harming noise.



Explosion risk!

Apparently harmless substances in closed containers may generate excessive pressure when heated.

- Move containers with inflammable or explosive liquids away from the working area!
- Never heat explosive liquids, dusts or gases by welding or cutting!



Fire hazard!

Due to the high temperatures, sparks, glowing parts and hot slag that occur during welding, there is a risk of flames.

- Be watchful of potential sources of fire in the working area!
- Do not carry any easily inflammable objects, e.g. matches or lighters.
- Ensure suitable fire extinguishers are available in the working area!
- Thoroughly remove any residue of flammable materials from the workpiece prior to starting to weld.
- Only further process workpieces after they have cooled down. Do not allow them to contact any flammable materials!

⚠ CAUTION**Smoke and gases!**

Smoke and gases may lead to shortness of breath and poisoning! The ultraviolet radiation of the arc may also convert solvent vapours (chlorinated hydrocarbon) into poisonous phosgene.

- Ensure sufficient fresh air!
- Keep solvent vapours away from the arc beam field!
- Wear suitable respiratory protection if necessary!
- To prevent the formation of phosgene, residues of chlorinated solvents on workpieces must first be neutralised using appropriate measures.

**Noise exposure!**

Noise exceeding 70 dBA can cause permanent hearing damage!

- Wear suitable ear protection!
- Persons located within the working area must wear suitable ear protection!



According to IEC 60974-10, welding machines are divided into two classes of electromagnetic compatibility (the EMC class can be found in the Technical data) > see 8 chapter:



Class A machines are not intended for use in residential areas where the power supply comes from the low-voltage public mains network. When ensuring the electromagnetic compatibility of class A machines, difficulties can arise in these areas due to interference not only in the supply lines but also in the form of radiated interference.



Class B machines fulfil the EMC requirements in industrial as well as residential areas, including residential areas connected to the low-voltage public mains network.

Setting up and operating

When operating arc welding systems, in some cases, electro-magnetic interference can occur although all of the welding machines comply with the emission limits specified in the standard. The user is responsible for any interference caused by welding.

In order to **evaluate** any possible problems with electromagnetic compatibility in the surrounding area, the user must consider the following: (see also EN 60974-10 Appendix A)

- Mains, control, signal and telecommunication lines
- Radios and televisions
- Computers and other control systems
- Safety equipment
- The health of neighbouring persons, especially if they have a pacemaker or wear a hearing aid
- Calibration and measuring equipment
- The immunity to interference of other equipment in the surrounding area
- The time of day at which the welding work must be carried out

Recommendations for reducing interference emission

- Mains connection, e.g. additional mains filter or shielding with a metal tube
- Maintenance of the arc welding system
- Welding leads should be as short as possible and run closely together along the ground
- Potential equalization
- Earthing of the workpiece. In cases where it is not possible to earth the workpiece directly, it should be connected by means of suitable capacitors.
- Shielding from other equipment in the surrounding area or the entire welding system

**Electromagnetic fields!**

The power source can create electrical or electromagnetic fields that may impair the function of electronic systems such as EDP and CNC devices, telecommunication, power and signal lines as well as pacemakers and defibrillators.



- Follow the maintenance instructions > see 6.3 chapter!
- Unwind the welding leads completely!
- Shield radiation-sensitive equipment or facilities appropriately!
- The function of pacemakers may be impaired (seek medical advice if necessary).

CAUTION



Obligations of the operator!

The respective national directives and laws must be complied with when operating the machine!

- Implementation of national legislation relating to framework directive 89/391/EEC on the introduction of measures to encourage improvements in the safety and health of workers at work and associated individual guidelines.
- In particular, directive 89/655/EEC concerning the minimum safety and health requirements for the use of work equipment by workers at work.
- The regulations applicable to occupational safety and accident prevention in the country concerned.
- Setting up and operating the machine as per IEC 60974.-9.
- Brief the user on safety-conscious work practices on a regular basis.
- Regularly inspect the machine as per IEC 60974.-4.



The manufacturer's warranty becomes void if non-genuine parts are used!

- ***Only use system components and options (power sources, welding torches, electrode holders, remote controls, spare parts and replacement parts, etc.) from our range of products!***
- ***Only insert and lock accessory components into the relevant connection socket when the machine is switched off.***

Requirements for connection to the public mains network

High-performance machines can influence the mains quality by taking current from the mains network. For some types of machines, connection restrictions or requirements relating to the maximum possible line impedance or the necessary minimum supply capacity at the interface with the public network (Point of Common Coupling, PCC) can therefore apply. In this respect, attention is also drawn to the machines' technical data. In this case, it is the responsibility of the operator, where necessary in consultation with the mains network operator, to ensure that the machine can be connected.

2.4 Transport and installation

WARNING



Risk of injury due to improper handling of shielding gas cylinders!

Improper handling and insufficient securing of shielding gas cylinders can cause serious injuries!

- Observe the instructions from the gas manufacturer and any relevant regulations concerning the use of compressed air!
- Do not attach any element to the shielding gas cylinder valve!
- Prevent the shielding gas cylinder from heating up.

⚠ CAUTION



Risk of accidents due to supply lines!

During transport, attached supply lines (mains leads, control cables, etc.) can cause risks, e.g. by causing connected machines to tip over and injure persons!

- Disconnect all supply lines before transport!



Risk of tipping!

There is a risk of the machine tipping over and injuring persons or being damaged itself during movement and set up. Tilt resistance is guaranteed up to an angle of 10° (according to IEC 60974-1).

- Set up and transport the machine on level, solid ground.
- Secure add-on parts using suitable equipment.



Risk of accidents due to incorrectly installed leads!

Incorrectly installed leads (mains, control and welding leads or intermediate hose packages) can present a tripping hazard.

- Lay the supply lines flat on the floor (avoid loops).
- Avoid laying the leads on passage ways.



Risk of injury from heated coolant and its connections!

The coolant used and its connection or connection points can heat up significantly during operation (water-cooled version). When opening the coolant circuit, escaping coolant may cause scalding.

- Open the coolant circuit only when the power source or cooling unit is switched off!
- Wear proper protective equipment (protective gloves)!
- Seal open connections of the hose leads with suitable plugs.



The units are designed for operation in an upright position!

Operation in non-permissible positions can cause equipment damage.

- ***Only transport and operate in an upright position!***



Accessory components and the power source itself can be damaged by incorrect connection!

- ***Only insert and lock accessory components into the relevant connection socket when the machine is switched off.***
- ***Comprehensive descriptions can be found in the operating instructions for the relevant accessory components.***
- ***Accessory components are detected automatically after the power source is switched on.***



Protective dust caps protect the connection sockets and therefore the machine against dirt and damage.

- ***The protective dust cap must be fitted if there is no accessory component being operated on that connection.***
- ***The cap must be replaced if faulty or if lost!***

3 Intended use

⚠ WARNING



Hazards due to improper usage!

The machine has been constructed to the state of the art and any regulations and standards applicable for use in industry and trade. It may only be used for the welding procedures indicated at the rating plate. Hazards may arise for persons, animals and material objects if the equipment is not used correctly. No liability is accepted for any damages arising from improper usage!

- The equipment must only be used in line with its designated purpose and by trained or expert personnel!
- Do not improperly modify or convert the equipment!

3.1 Use and operation solely with the following machines

A suitable wire feed unit (system component) is required in order to operate the welding machine!

The following system components can be combined with this machine:

- Drive XQ AC

3.2 Applications

Multi-process welding machine for arc welding covering the following welding procedures:

Machine series	Main procedure for MIG/MAG welding										Secondary procedure				
	Standard arc					Pulsed arc					TIG welding (Liftarc)	MMA welding	Gouging	Positionweld	
	MIG/MAG XQ	forceArc XQ	rootArc XQ	coldArc XQ	wiredArc XQ	MIG/MAG pulse XQ	forceArc puls XQ	rootArc puls XQ	coldArc puls XQ	acArc puls XQ					wiredArc puls XQ
Titan XQ AC	✓	✓	✓	✓	✓	✓	✓	✓	✓	✓	✓	✓	✓	✓	✓
Titan XQ / XQ C	✓	✓	✓	✓	✓	✓	✓	✓	✓	✗	✓	✓	✓	✓	✓
Phoenix XQ / XQ C	✓	✓	✓	✗	✗	✓	✓	✓	✗	✗	✗	✓	✓	✓	✓ ^[1]
Taurus XQ / XQ C	✓	✓	✓	✗	✗	✗	✗	✗	✗	✗	✗	✓	✓	✓	✗
Taurus XQ Basic	✓	✗	✗	✗	✗	✗	✗	✗	✗	✗	✗	✓	✓	✓	✗

^[1] Aluminium-welding tasks

3.3 Documents which also apply

3.3.1 Warranty

For more information refer to the "Warranty registration" brochure supplied and our information regarding warranty, maintenance and testing at www.ewm-group.com!

3.3.2 Declaration of Conformity



This product corresponds in its design and construction to the EU directives listed in the declaration. The product comes with a relevant declaration of conformity in the original.

The manufacturer recommends carrying out the safety inspection according to national and international standards and guidelines every 12 months (from commissioning).

3.3.3 Welding in environments with increased electrical hazards



Power sources with this marking can be used for welding in an environment with increased electrical hazard (e.g. boilers). For this purpose, appropriate national or international regulations must be followed. The power source must not be placed in the danger zone!

3.3.4 Service documents (spare parts and circuit diagrams)

WARNING



No improper repairs and modifications!

To prevent injuries and damage to the machine, only competent personnel (authorised service personnel) are allowed to repair or modify the machine.

Unauthorised manipulations will invalidate the warranty!

- Instruct competent personnel (authorised service personnel) to repair the machine.

Original copies of the circuit diagrams are enclosed with the unit.

Spare parts can be obtained from the relevant authorised dealer.

3.3.5 Calibration/Validation

An original certificate is enclosed with the product. The manufacturer recommends calibration / validation at intervals of 12 months (from commissioning).

3.3.6 Part of the complete documentation

This document is part of the complete documentation and valid only in combination with all other parts of these instructions! Read and observe the operating instructions for all system components, especially the safety instructions!

The illustration shows a general example of a welding system.

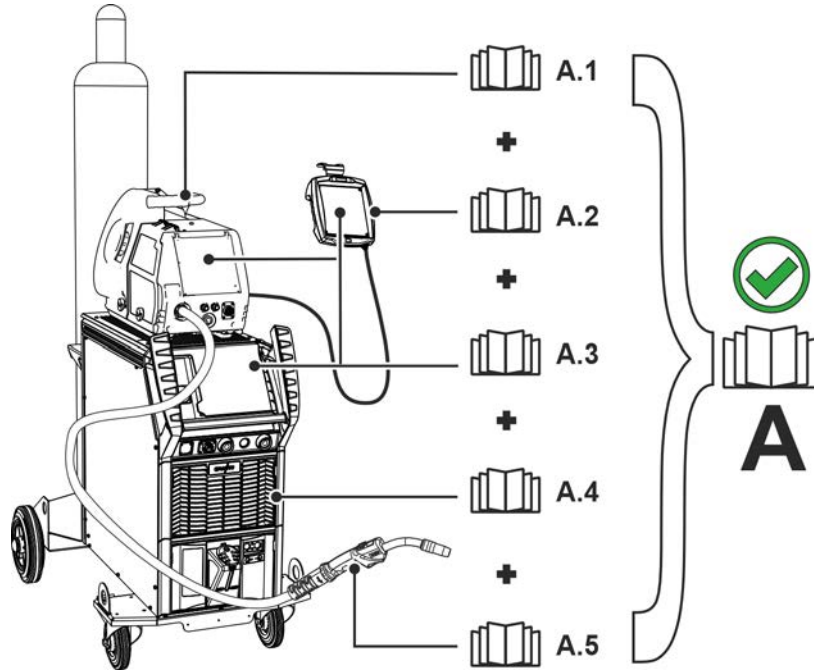

Figure 3-1

Item	Documentation
A.1	Wire feed unit
A.2	Remote control
A.3	Control
A.4	Power source
A.5	Welding torch
A	Complete documentation

4 Machine description – quick overview

4.1 Machine configuration

The following table shows the different design variants (expansion stages) of the device series XQ:

Type			Figure	Transport properties				Torch cooling		
				Wheel kit, narrow track, without cylinder bracket	Pallet bottom, without cylinder bracket	Wheel kit, single cylinder bracket	Wheel kit, double cylinder bracket	Gas	Water (coolant)	Water (coolant), reinforced pump
F06	R1	G		✗	✗	✓	✗	✓	✗	✗
F06	R1	W		✗	✗	✓	✗	✗	✓	✗
F06	R1	WRF		✗	✗	✓	✗	✗	✗	✓
F06	R2	G		✗	✗	✗	✓	✓	✗	✗
F06	R2	W		✗	✗	✗	✓	✗	✓	✗
F06	R2	WRF		✗	✗	✗	✓	✗	✗	✓
F06	RS	G		✓	✗	✗	✗	✓	✗	✗
F06	RS	W		✓	✗	✗	✗	✗	✓	✗
F06	RS	WRF		✓	✗	✗	✗	✗	✗	✓
F06	P	G		✗	✓	✗	✗	✓	✗	✗
F06	P	W		✗	✓	✗	✗	✗	✓	✗
F06	P	WRF		✗	✓	✗	✗	✗	✗	✓

Figure 4-1

4.2 Front view / side view from the right

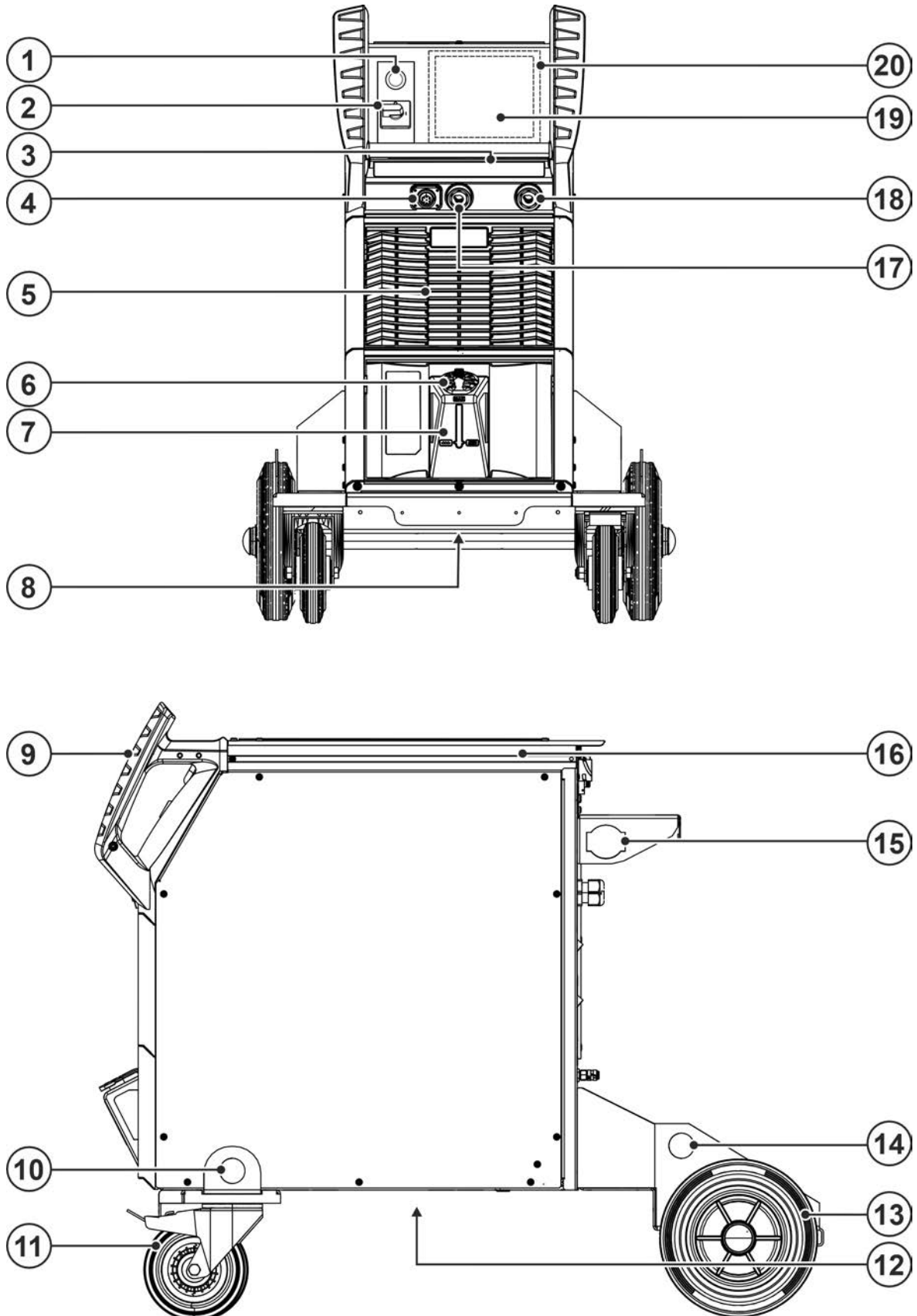





Figure 4-2

Item	Symbol	Description
1		WiFi antenna Factory-fit option, (version OW Expert XQ 2.0 WLG)
2		Main Switch Switching the machine on or off.
3		LED status bar - display of operating status The operating status is indicated by a light guide > see 5.1.10.1 chapter.
4		7-pole connection socket - digital For connecting digital accessory components
5		Cooling air outlet
6		Coolant tank cap
7		Coolant tank > see 5.1.5 chapter
8		Coolant drain plug > see 6.3.2 chapter
9		Carrying handle
10		Lifting lug > see 5.1.1 chapter
11		Wheels with locking brake
12		Inlet opening for cooling air - torch cooling Dirt filter can be retrofitted
13		Wheels - fixed castors
14		Lifting lug > see 5.1.1 chapter
15		Intermediate hose package strain relief > see 5.2.1.1 chapter
16		Aluminium extrusion profile flexFit Individual mounting option for accessories and options
17		Connection socket (+) welding current How to connect the accessories depends on the welding procedure. Please observe the connection description for the corresponding welding procedure > see 5 chapter.
18		Connection socket (-) welding current How to connect the accessories depends on the welding procedure. Please observe the connection description for the corresponding welding procedure > see 5 chapter.
19		Machine control (see the relevant control operating instructions)
20		Protective cap > see 5.1.11 chapter

4.3 Rear view / side view from left

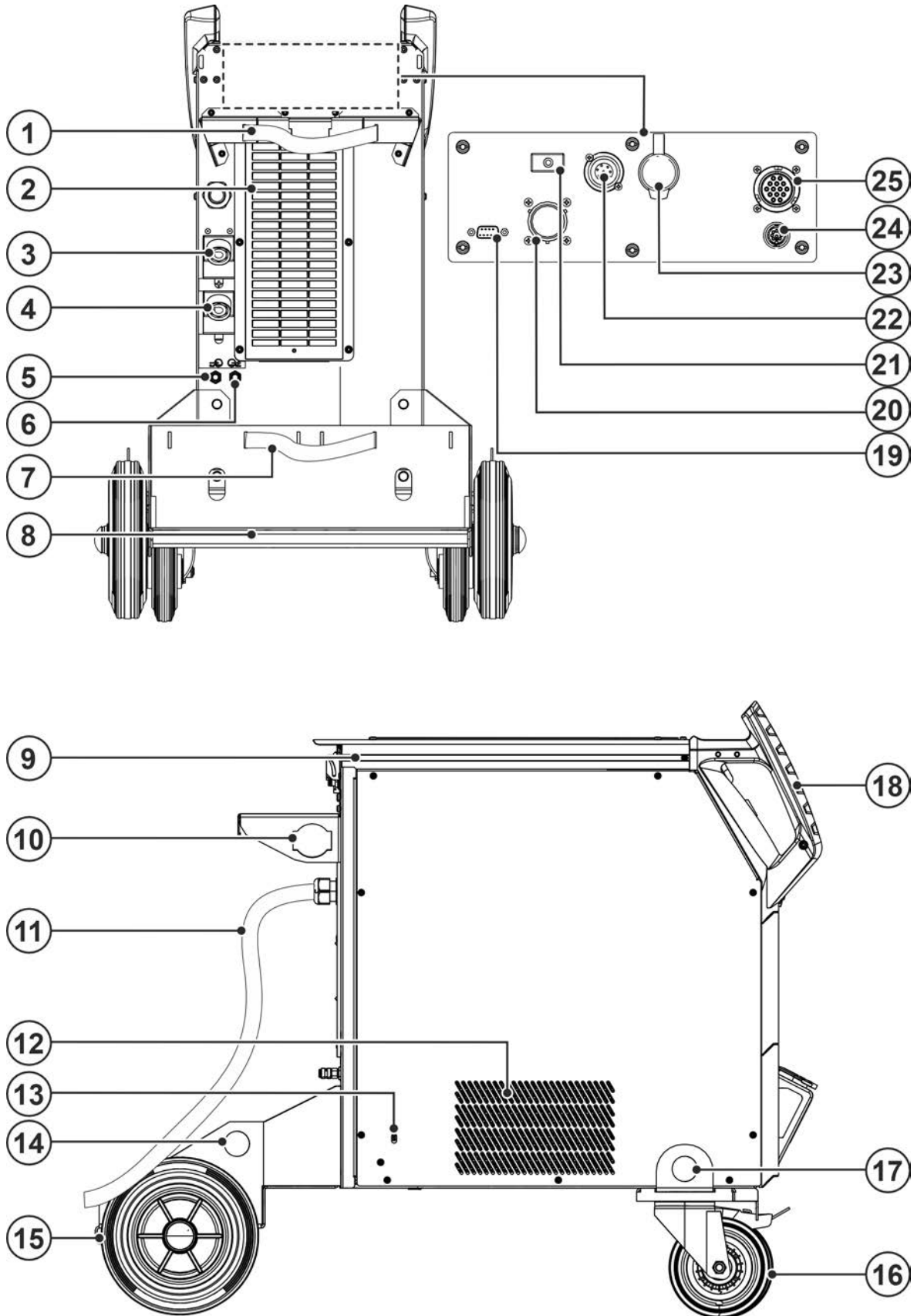













Figure 4-3

Item	Symbol	Description
1		Securing elements for shielding gas cylinder (strap/chain)
2		Cooling air inlet Dirt filter optional > see 6.3.1 chapter
3		Connection socket (+) welding current How to connect the accessories depends on the welding procedure. Please observe the connection description for the corresponding welding procedure > see 5 chapter.
4		Connection socket (-) welding current How to connect the accessories depends on the welding procedure. Please observe the connection description for the corresponding welding procedure > see 5 chapter.
5		Quick connect coupling - red coolant return
6		Quick connect coupling - blue coolant supply
7		Securing elements for shielding gas cylinder (strap/chain)
8		Bracket for shielding gas cylinder
9		Aluminium extrusion profile flexFit Individual mounting option for accessories and options
10		Intermediate hose package strain relief > see 5.2.1.1 chapter
11		Mains connection cable > see 5.1.9 chapter
12		Outlet opening cooling air - torch cooling
13		Service opening for coolant pump > see 7.5 chapter
14		Lifting lug > see 5.1.1 chapter
15		Wheels - fixed castors
16		Wheels - guide castors
17		Lifting lug > see 5.1.1 chapter
18		Carrying handle
19		Connection socket 9-pole - D-Sub PC interface > see 5.7 chapter
20		Connection socket 19-pole - analogue - optional Interface for automated welding > see 5.6.1 chapter
21		Key button, Automatic cutout Wire feed motor supply voltage fuse (press to reset a triggered fuse)
22		7-pole connection socket - digital For connecting digital accessory components
23		Connection socket - RJ45 - Option Network connection > see 5.9 chapter
24		Connection socket for hand scanner - optional Component identification Xnet > see 5.8 chapter
25		14-pole connection socket Wire feeder control cable connection DV1

5 Design and function

⚠ WARNING



Risk of injury from electrical voltage!

Contact with live parts, e.g. power connections, can be fatal!

- Observe the safety information on the first pages of the operating instructions!
- Commissioning must be carried out by persons who are specifically trained in handling power sources!
- Connect connection or power cables while the machine is switched off!

Read and observe the documentation to all system and accessory components!

5.1 Transport and installation

5.1.1 Lifting by crane

⚠ WARNING



Risk of injury during lifting by crane!

When lifting the machine by crane, persons may be severely injured by falling machines or mount-on components.

- Simultaneous lifting of system components such as power source, wire feeder or cooling unit without suitable crane components is not allowed. Each system component has to be lifted separately!
- Remove any supply leads and accessories before lifting by crane (e.g. hose package, wire spool, shielding gas cylinder, toolbox, wire feeder, remote control, etc.)!
- Properly close and lock all casing covers and protective caps before lifting by crane!
- Use the correct number of hoisting equipment of the right size in the correct position! Observe craning principle > see 5.1.1.1 chapter!
- Devices with lifting eyes: Always lift all lifting eyes simultaneously!
- Devices with pallet bottom (feet): Pull the straps through the openings of the feet (hooking hoisting equipment in the openings is not sufficient).
- When using retrofitted craning frames etc.: always use at least two lifting points positioned as far apart as possible – observe option description.
- Avoid any jerky movements!
- Ensure that the load is distributed evenly! • Use chain hoists and chain slings of the same length only!
- Stay outside the danger zone underneath the machine!
- Observe the regulations regarding occupational safety and accident prevention for the respective country.

5.1.1.1 Craning principle

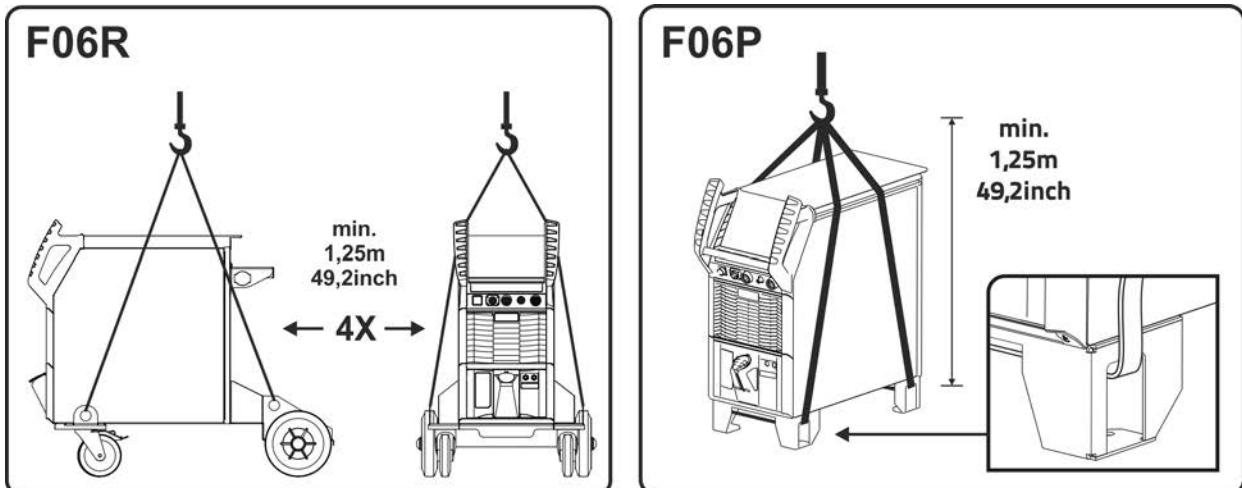

Figure 5-1

5.1.2 Ambient conditions



The machine must not be operated in the open air and must only be set up and operated on a suitable, stable and level base!

- **The operator must ensure that the ground is non-slip and level, and provide sufficient lighting for the place of work.**
- **Safe operation of the machine must be guaranteed at all times.**



Machine damage due to contamination!

Unusually high amounts of dust, acid, corrosive gas or substances may damage the machine (note the maintenance intervals > see 6.3 chapter).

- **Prevent high amounts of smoke, weld spatter, steam, oil vapour, grinding dust and corrosive ambient air from developing!**

In operation

Temperature range of the ambient air:

- -25 °C to +40 °C (-13 °F to 104 °F) ^[1]

Relative humidity:

- up to 50 % at 40 °C (104 °F)
- up to 90 % at 20 °C (68 °F)

Transport and storage

Storage in a closed room, temperature range of the ambient air:

- -30 °C to +70 °C (-22 °F to 158 °F) ^[1]

Relative humidity

- up to 90 % at 20 °C (68 °F)

^[1] Ambient temperature dependent on coolant! Observe the coolant temperature range of the torch cooling

5.1.3 Machine cooling



Insufficient ventilation results in a reduction in performance and equipment damage.

- **Observe the ambient conditions!**
- **Keep the cooling air inlet and outlet clear!**
- **Observe the minimum distance of 0.5 m from obstacles!**

5.1.4 Workpiece lead, general

CAUTION



Risk of burning due to incorrect welding current connection!

If the welding current plugs (machine connections) are not locked or if the workpiece connection is contaminated (paint, corrosion), these connections and leads can heat up and cause burns when touched!

- Check welding current connections on a daily basis and lock by turning to the right when necessary.
- Clean workpiece connection thoroughly and secure properly. Do not use structural parts of the workpiece as welding current return lead!

5.1.5 Welding torch cooling system



Material damage due to unsuitable coolants!

Unsuitable coolant, coolants mixed with other types / liquids or use in an unsuitable temperature range will result in material damage and loss of the manufacturer's warranty!

- **Operation without coolant is not permitted! Dry running will destroy the cooling components such as the coolant pump, welding torch and hose packages.**
- **Only use the coolants described in these instructions for the specified ambient conditions (temperature range) > see 5.1.5.2 chapter.**
- **Do not mix coolants of different types (including those described in these instructions).**
- **When changing the coolant, all liquid must be replaced and the cooling system flushed.**

Dispose of the coolant in accordance with local regulations and the material safety data sheets.

5.1.5.1 Functional characteristics

The cooling system of this machine series is designed to optimise the operating conditions and is temperature- and flow-monitored to protect against damage. Limit values > see 8.1.2 chapter for warnings and errors in the machine (adjustable depending on control system) are stored for monitoring and control of the cooling system. If the cooling system is faulty or overloaded, an error message appears and the welding process is switched off in a controlled manner.

5.1.5.2 Permitted torch coolant

Coolant	Temperature range
blueCool -10	-10 °C to +40 °C (14 °F to +104 °F)
blueCool -30	-30 °C to +40 °C (-22 °F to +104 °F)

5.1.5.3 Maximal hose package length

All information relates to the total hose package length of the complete welding system and presents exemplary configurations (of components of the EWM product portfolio with standard lengths). A straight kink-free installation is to be ensured, taking into account the max. delivery height.

Pump: Pmax = 3,5 bar (0.35 MPa)

Power source	Hose package	Wire feeder	miniDrive	Welding torch	Max.
Compact	✘	✘	✔ (25 m / 82 ft.)	✔ (5 m / 16 ft.)	30 m 98 ft.
	✔ (20 m / 65 ft.)	✔	✘	✔✔ (5 m / 16 ft.)	
Decompact	✔ (25 m / 82 ft.)	✔	✘	✔ (5 m / 16 ft.)	
	✔ (15 m / 49 ft.)	✔	✔ (10 m / 32 ft.)	✔ (5 m / 16 ft.)	

Pump: Pmax = 4.5 bar (0.45 MPa)

Power source	Hose package	Wire feeder	miniDrive	Welding torch	Max.
Compact	✘	✘	✔ (25 m / 82 ft.)	✔ (5 m / 16 ft.)	30 m 98 ft.
	✔ (30 m / 98 ft.)	✔	✘	✔✔ (5 m / 16 ft.)	40 m 131 ft.
Decompact	✔ (40 m / 131 ft.)	✔	✘	✔ (5 m / 16 ft.)	45 m 147 ft.
	✔ (40 m / 131 ft.)	✔	✔ (25 m / 82 ft.)	✔ (5 m / 16 ft.)	70 m 229 ft.

For optimum welding results, a maximum cable length of 30 meters (workpiece lead+ intermediate hose package + torch hose package) should be used. Ensure the proper routing of the welding power leads > see 5.1.6 chapter.

5.1.5.4 Adding coolant

After switching on the machine, the coolant pump runs for a defined time (filling the hose package). If the machine does not detect sufficient coolant flow during this time, the coolant pump is switched off (protection against damage caused by dry running). At the same time, the welding data display signals the coolant error. If there is sufficient coolant flow, the coolant pump is switched off before the defined time has elapsed (operational readiness).

If there is less coolant in the coolant tank than the minimum required you may need to vent the coolant circuit. In this case the welding machine will automatically shut down the coolant pump and signal an error, > see 7.4 chapter.

The unit is supplied ex works with a minimum level of coolant.

The level of coolant must never fall below the "MIN" mark.

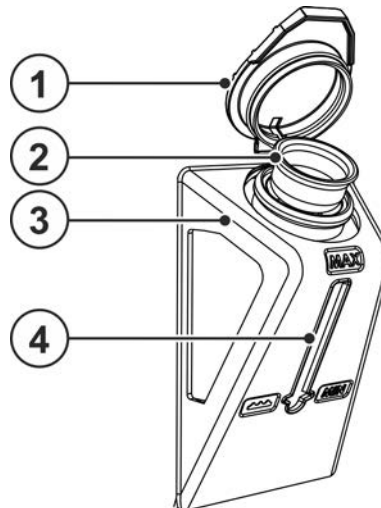

Figure 5-2

Item	Symbol	Description
1		Coolant tank cap
2		Coolant filter sieve
3		Coolant tank > see 5.1.5 chapter
4		Filling level display MIN -----minimum coolant level MAX -----maximum coolant level

- Pull off the coolant tank sealing cover.
- Check filter sieve for cleanliness, clean if necessary and reinsert.
- Top up coolant up to the upper filling level gauge "MAX" and push sealing cover back on.
- Switch on the power source at the main switch.

5.1.6 Notes on the installation of welding current leads

- Incorrectly installed welding current leads can cause faults in the arc (flickering).
- Lay the workpiece lead and hose package of power sources without HF igniter (MIG/MAG) for as long and as close as possible in parallel.
- Lay the workpiece lead and hose package of power sources with HF igniter (TIG) for as long as possible in parallel with a distance of 20 cm to avoid HF sparkover.
- Always keep a distance of at least 20 cm to leads of other power sources to avoid interferences
- Always keep leads as short as possible! For optimum welding results max. 30 m (welding lead + intermediate hose package + torch lead).

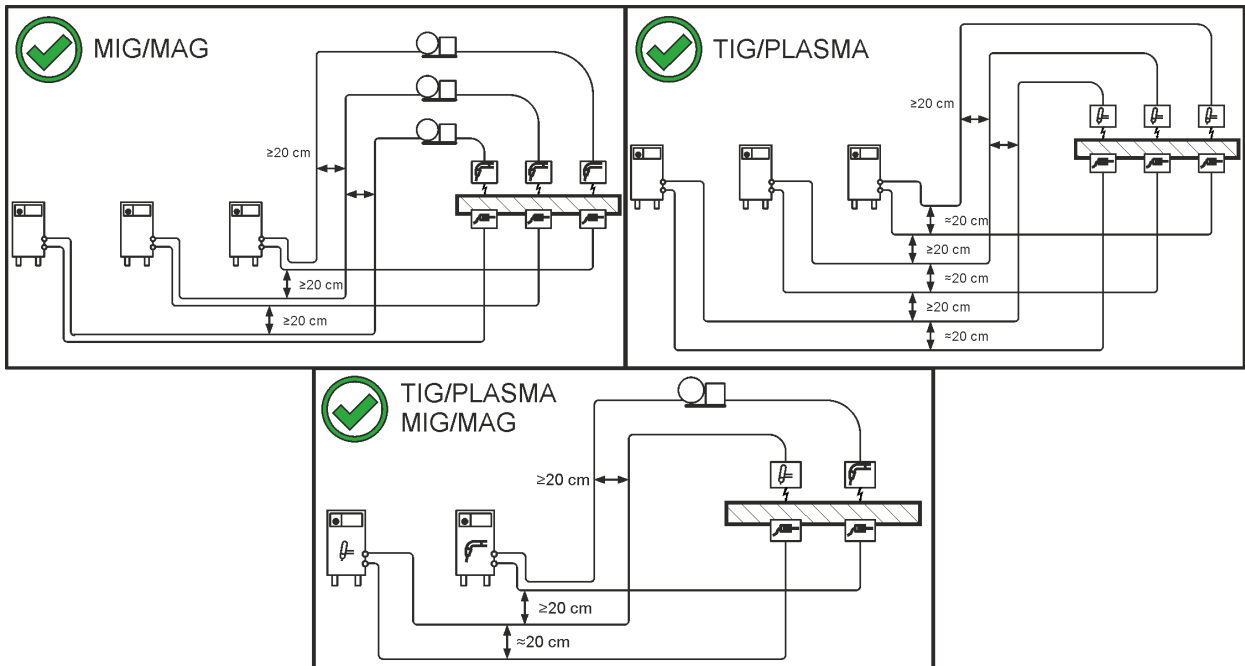

Figure 5-3

- Use an individual welding lead to the workpiece for each welding machine!

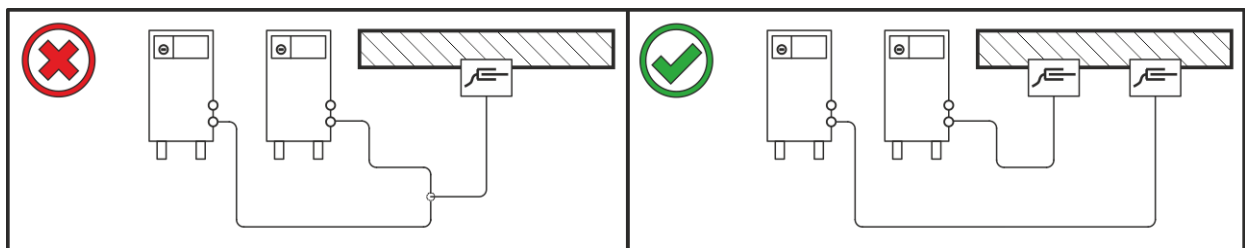

Figure 5-4

- Fully unroll welding current leads, torch hose packages and intermediate hose packages. Avoid loops!
- Always keep leads as short as possible!

Lay any excess cable lengths in meanders.

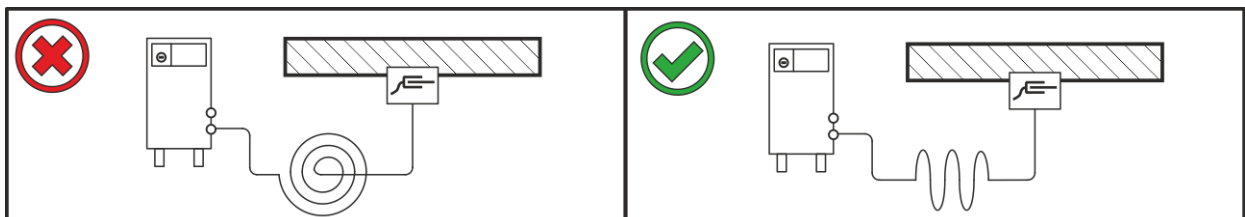

Figure 5-5

5.1.7 Stray welding currents

⚠ WARNING



Risk of injury due to stray welding currents!

Stray welding currents can destroy protective earth conductors, damage machines and electronic devices and cause overheating of components, leading to fire.

- Check that all welding current connections are firmly secured and electrical connections are in perfect condition.
- Set up, attach or suspend all conductive power source components such as casing, transport vehicles and crane frames so they are insulated.
- Do not place any other electronic devices such as drills or angle grinders on the power source, transport vehicle or crane frames unless they are insulated.
- Always put welding torches and electrode holders on an insulated surface when they are not in use.

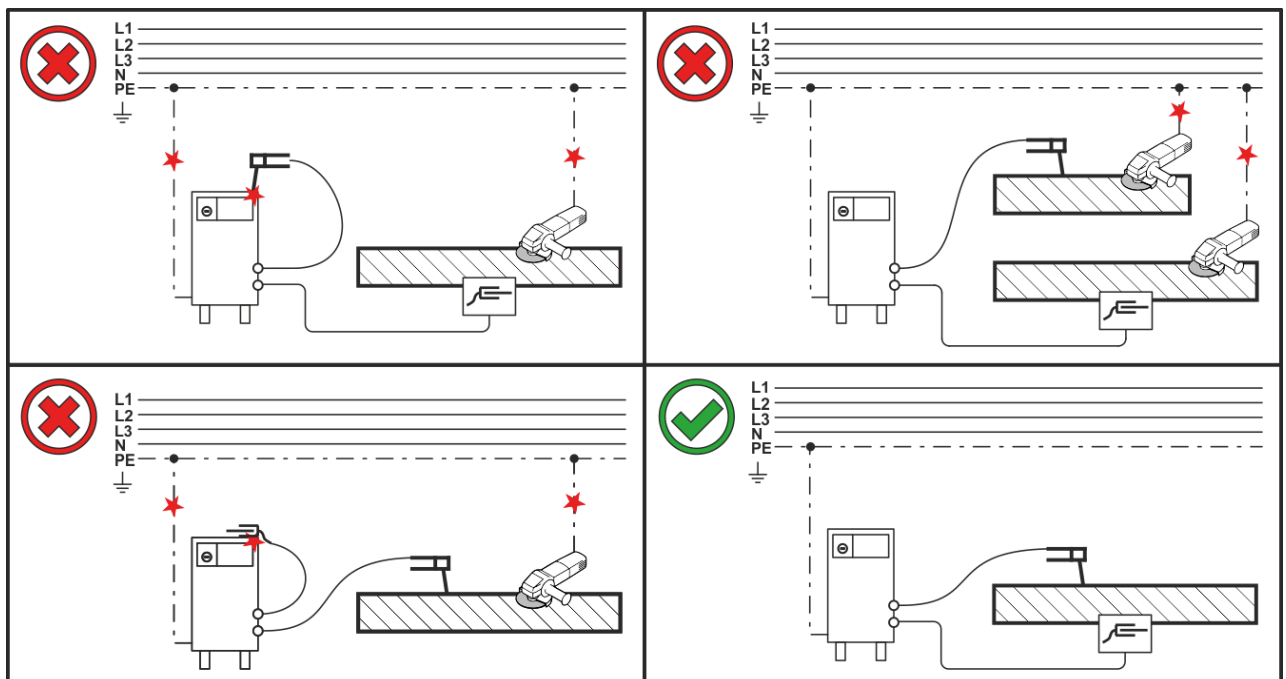

Figure 5-6

5.1.8 Shielding gas supply (shielding gas cylinder for welding machine)

⚠ WARNING



Risk of injury due to improper handling of shielding gas cylinders!

Improper handling and insufficient securing of shielding gas cylinders can cause serious injuries!

- Observe the instructions from the gas manufacturer and any relevant regulations concerning the use of compressed air!
- Lift the shielding gas cylinder onto the receptacle of the shielding gas cylinder and secure with both safety belts provided on the device as standard! Belts must be tight.
- Do not attach any element to the shielding gas cylinder valve!
- Prevent the shielding gas cylinder from heating up.

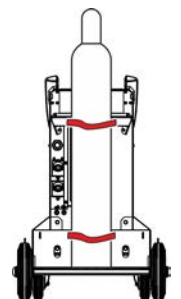

An unimpeded shielding gas supply from the shielding gas cylinder to the welding torch is a fundamental requirement for optimum welding results. In addition, a blocked shielding gas supply may result in the welding torch being destroyed.

- **All shielding gas connections must be gas tight.**

5.1.8.1 Pressure regulator connection

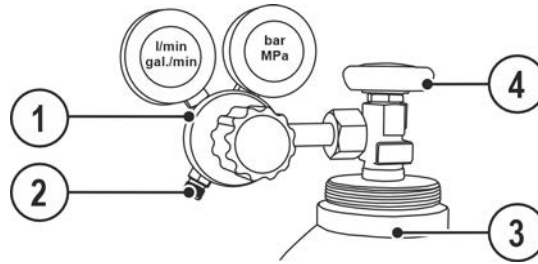

Figure 5-7

Item	Symbol	Description
1		Pressure regulator
2		Output side of the pressure regulator
3		Shielding gas cylinder
4		Cylinder valve

- Before connecting the pressure regulator to the gas cylinder, open the cylinder valve briefly to blow out any dirt.
- Tighten the pressure regulator screw connection on the gas bottle valve to be gas-tight.
- Screw the gas hose connection to the outlet side of the pressure regulator gas-tight.

5.1.9 Mains connection

DANGER



Hazards caused by improper mains connection!

An improper mains connection can cause injuries or damage property!

- The connection (mains plug or cable), the repair or voltage adjustment of the device must be carried out by a qualified electrician in accordance with the respective local laws or national regulations!
- The mains voltage indicated on the rating plate must match the supply voltage.
- Only operate machine using a socket that has correctly fitted protective earth.
- Mains plug, socket and lead must be checked by a qualified electrician on a regular basis!
- When operating the generator, always ensure it is earthed as stipulated in the operating instructions. The network created must be suitable for operating machines according to protection class I.

5.1.9.1 Mains configuration

The machine may be connected to:

- a three-phase system with four conductors and an earthed neutral conductor
- a three-phase system with three conductors of which any one can be earthed, e.g. the outer conductor

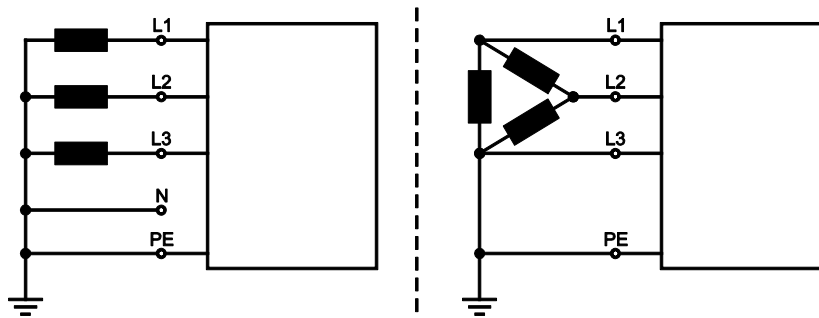

Figure 5-8

Legend

Item	Designation	Colour code
L1	Outer conductor 1	brown
L2	Outer conductor 2	black
L3	Outer conductor 3	grey
N	Neutral conductor	blue
PE	Protective conductor	green-yellow

- Insert mains plug of the switched-off machine into the appropriate socket.

5.1.10 Switching on and system diagnosis

Each time the system is switched on, the entire welding system runs data synchronization and the system diagnostics of the individual components. The duration of the start time (switching on up to welding readiness) depends on the number of connected system components and the information to be exchanged under these devices. This time can take from several seconds to several minutes (e.g. for the system components interconnected for the first time). During this start phase, the system components will display the controller type and, if applicable, software information in the welding data display (if available). This start phase is terminated by display of the nominal values for current, voltage or wire feed speed.

Operation of machine fan and coolant pump

The machine fan and coolant pump in this machine series are temperature- and state-controlled. This ensures that subsystems of the welding machine run only when they are needed. After each switching on, the machine fans run at full power for approx. 2 s, e.g. to blow out dust deposits.

5.1.10.1 LED status bar - display of operating status

A light guide on the front of the housing (LED status bar) shows the user the current operating status of the device.

Colour of the LED status bar	Operating status
white (change: light/dark)	Booting (switching on up to welding readiness)
blue	Ready for welding
blue (change: light/dark)	Power-saving mode Standby
green	Welding
yellow	Warning > see 7.2 chapter
red	Error > see 7.1 chapter

5.1.11 Protective flap, welding machine control

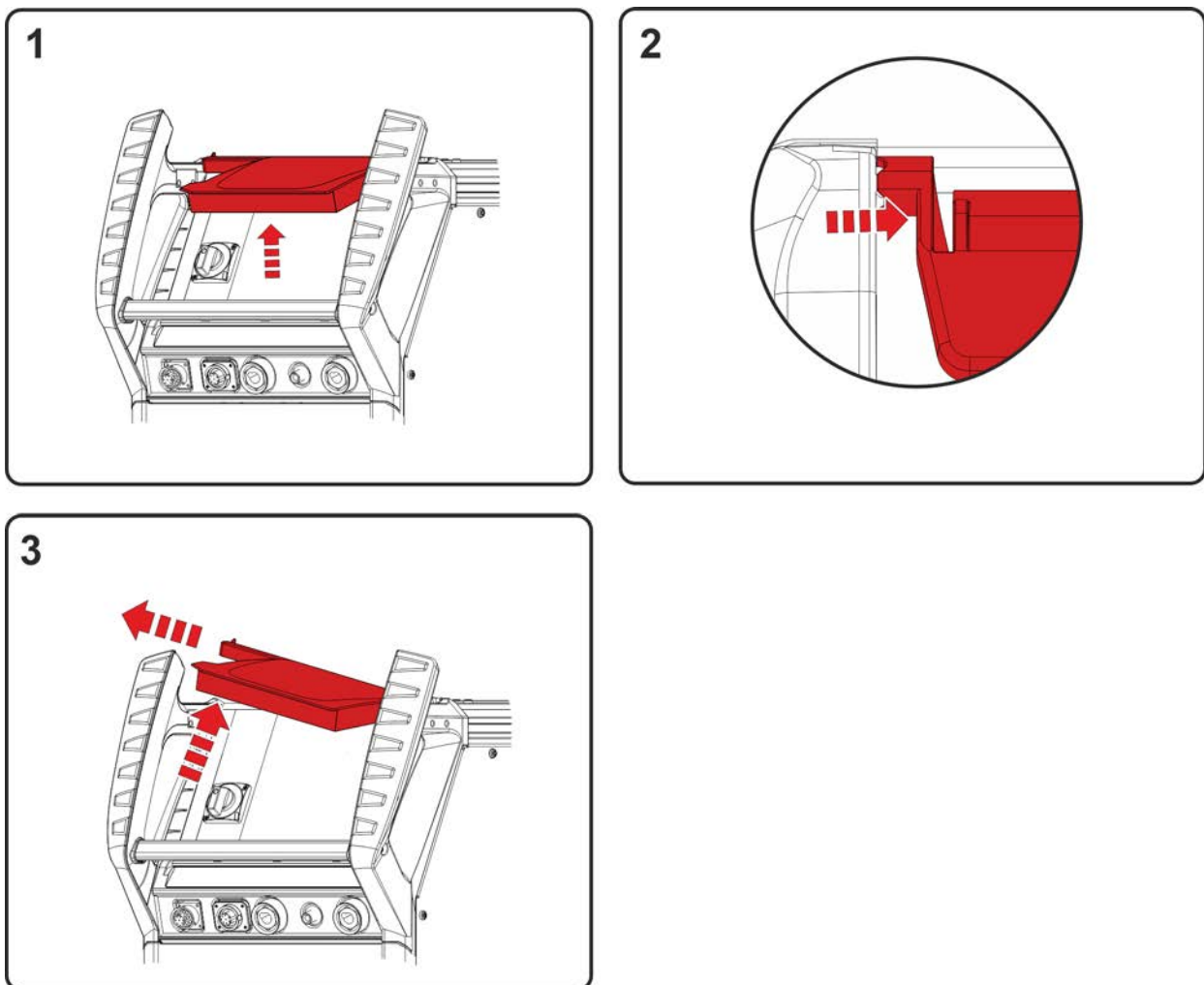

Figure 5-9

- Open the protective cap.
- Apply slight pressure on the left connecting bridge (figure) until the flap's fastening pin can be removed to the left, from top.

5.2 MIG/MAG welding

5.2.1 Connecting the intermediate hose package to the power source

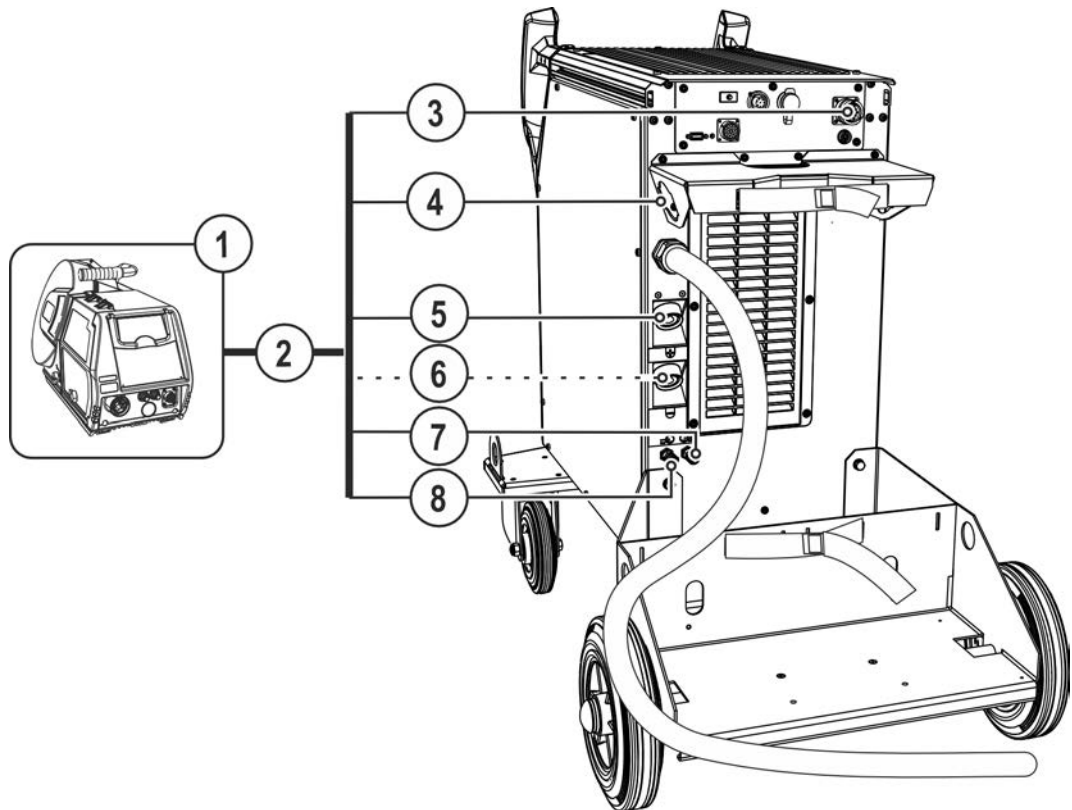

Figure 5-10

Item	Symbol	Description
1		Wire feed unit
2		Intermediate hose package
3		14-pole connection socket Wire feeder control cable connection
4		Intermediate hose package strain relief > see 5.2.1.1 chapter
5		Connection socket (+) welding current • Standard MIG/MAG welding (intermediate hose package)
6		Connection socket (-) welding current Connection for welding current plug from intermediate hose package • MIG/MAG flux cored wire welding • TIG welding
7		Quick connect coupling - blue coolant supply
8		Quick connect coupling - red coolant return

- Insert the hose package end of the intermediate hose package from the outside through the strain relief of intermediate hose package and then lock by turning to the right.
- Insert the control cable through the recess in the gas cylinder bracket, insert the cable plug into the into the connection socket (14-pole) and secure with crown nut (the plug can only be inserted into the connection socket in one position).
- Insert the plug on the welding current lead into the welding current connection socket "+" and lock.
- Lock connecting nipples of the cooling water tubes into the corresponding quick connect couplings: Return line red to quick connect coupling, red (coolant return) and supply line blue to quick connect coupling, blue (coolant supply).

Some wire electrodes (e.g. self-shielding cored wire) are welded using negative polarity. In this case, the welding current lead should be connected to the "-" welding current socket, and the workpiece lead should be connected to the "+" welding current socket. Observe the information from the electrode manufacturer!

5.2.1.1 Intermediate hose package strain relief



Property damage due to strain relief not installed or not installed correctly!

The strain relief absorbs tensile forces on cables, plugs and sockets.

If strain reliefs are not installed or not installed correctly, the connector plugs or sockets may be damaged.

- **The attachment must always take place on both sides of the intermediate hose package!**
- **The connections of the hose package must be locked properly!**

5.2.1.2 Possible attachment points

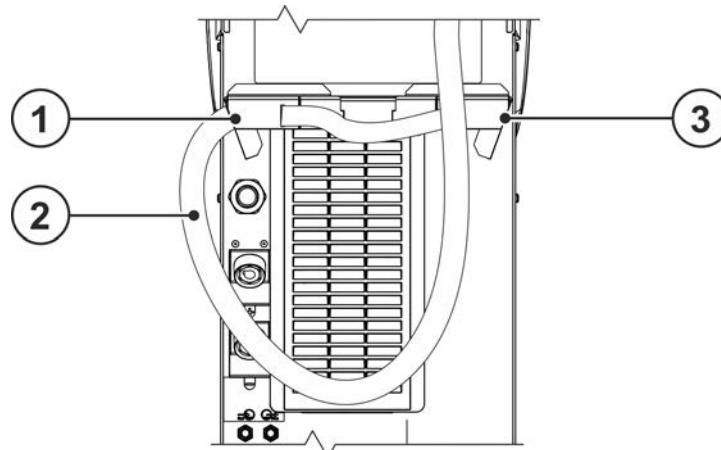

Figure 5-11

Item	Symbol	Description
1	DV1	Intermediate hose package strain relief For wire feeder 1
2		Intermediate hose package
3	DV2	Intermediate hose package strain relief For wire feeder 2

5.2.1.3 Locking the strain relief EWM intermediate hose package

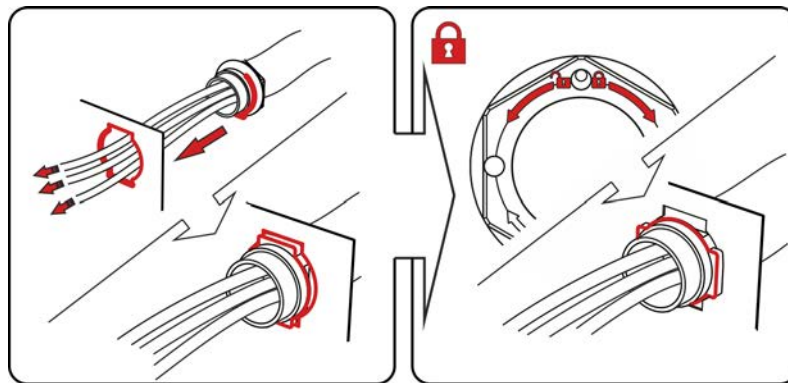

Figure 5-12

5.2.2 Connection for workpiece lead

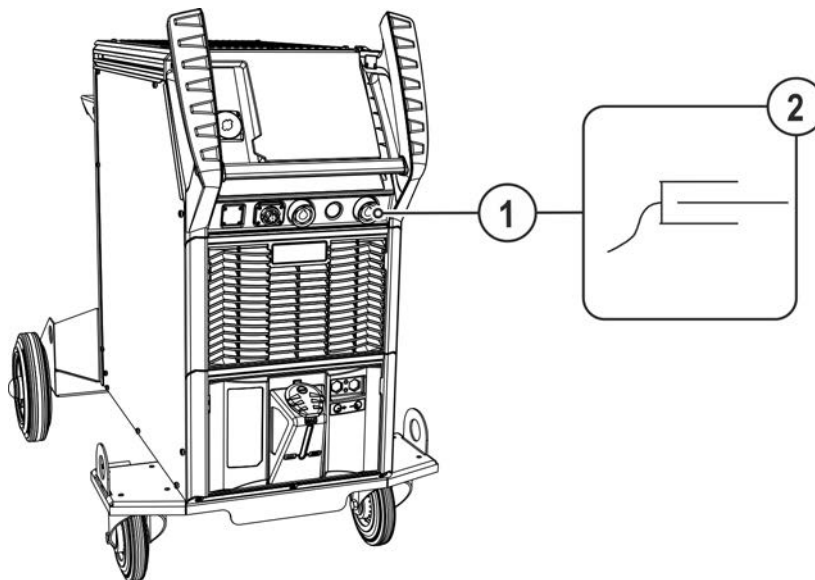

Figure 5-13

Item	Symbol	Description
1		Connection socket (-) welding current Workpiece lead connection
2		Workpiece

- Insert the plug on the workpiece lead into the "-" welding current connection socket and lock.
Some wire electrodes (e.g. self-shielding cored wire) are welded using negative polarity. In this case, the welding current lead should be connected to the "-" welding current socket, and the workpiece lead should be connected to the "+" welding current socket. Observe the information from the electrode manufacturer!

5.2.3 Setting the shielding gas volume (gas test)/rinse hose package

- Shielding gas supply as described in chapter Transport and positioning > see 5.1.8 chapter.
- Slowly open the gas cylinder valve.
- Open the pressure regulator.
- Switch on the power source at the main switch.
- Set the relevant gas quantity for the application on the pressure regulator.
- You can activate the gas test on the machine control (see Control operating instructions) or by pressing the "Gas test/rinse hose package" push-button briefly (welding voltage and wire feed motor remain switched off – no unintentional ignition of the arc). Some welding systems have several push-buttons to set the shielding gas. The push-button is generally found near a wire feeder.

Shielding gas flows for around 25 seconds or until the button is pressed again.

If the shielding gas setting is too low or too high, this can introduce air to the weld pool and may cause pores to form. Adjust the shielding gas quantity to suit the welding task!

Welding process	Recommended shielding gas quantity
MAG welding	Wire diameter x 11.5 = l/min
MIG brazing	Wire diameter x 11.5 = l/min
MIG welding (aluminium)	Wire diameter x 13.5 = l/min (100 % argon)

Helium-rich gas mixtures require a higher gas volume!

The table below can be used to correct the gas volume calculated where necessary:

Shielding gas	Factor
75% Ar/25% He	1.14
50% Ar/50% He	1.35
25% Ar/75% He	1.75
100% He	3.16

5.2.4 Welding task selection

For selection of the welding task and for general operation see the relevant Control operating instructions.

5.3 TIG welding

5.3.1 Connecting the intermediate hose package to the power source

TIG combi welding torches are connected to wire feed unit and power source. The welding current for the intermediate hose package must be connected to the welding current connection (-) at the rear of the unit!

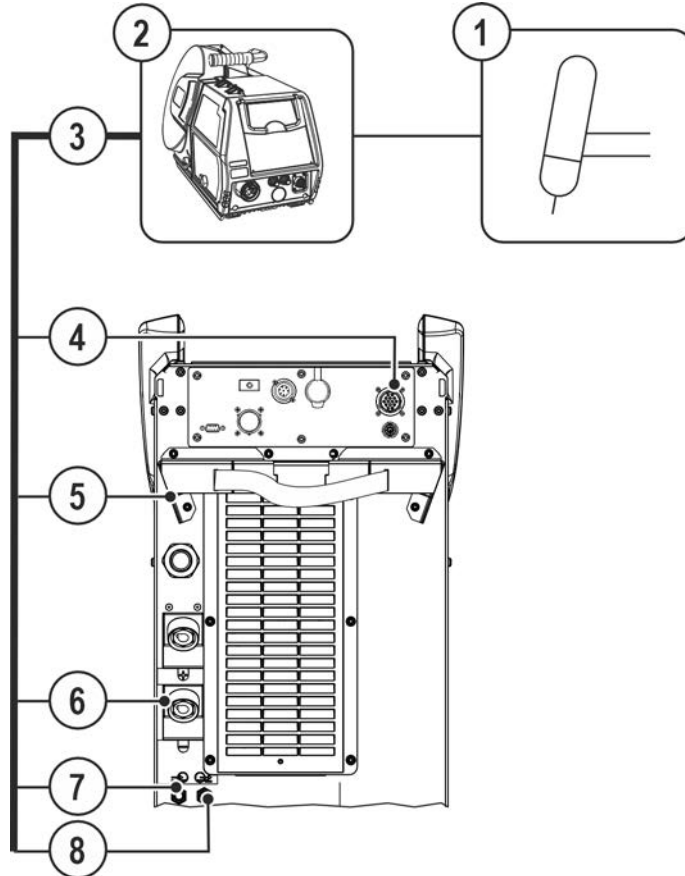

Figure 5-14

Item	Symbol	Description
1		Welding torch
2		Wire feed unit
3		Intermediate hose package
4	 DV1	14-pole connection socket Wire feeder control cable connection
5		Intermediate hose package strain relief > see 5.2.1.1 chapter
6		Connection socket (-) welding current Connection for welding current plug from intermediate hose package <ul style="list-style-type: none"> • MIG/MAG flux cored wire welding • TIG welding
7	 Red	Quick connect coupling - red coolant return
8	 Blue	Quick connect coupling - blue coolant supply

- Insert the hose package end of the intermediate hose package from the outside through the strain relief of intermediate hose package and then lock by turning to the right.
- Insert the control cable through the recess in the gas cylinder bracket, insert the cable plug into the into the connection socket (14-pole) and secure with crown nut (the plug can only be inserted into the connection socket in one position).
- Plug the welding current lead plug into the welding current "-" connection socket and lock.
- Lock connecting nipples of the cooling water tubes into the corresponding quick connect couplings: Return line red to quick connect coupling, red (coolant return) and supply line blue to quick connect coupling, blue (coolant supply).

5.3.2 Intermediate hose package strain relief



Property damage due to strain relief not installed or not installed correctly!

The strain relief absorbs tensile forces on cables, plugs and sockets.

If strain reliefs are not installed or not installed correctly, the connector plugs or sockets may be damaged.

- **The attachment must always take place on both sides of the intermediate hose package!**
- **The connections of the hose package must be locked properly!**

5.3.2.1 Possible attachment points

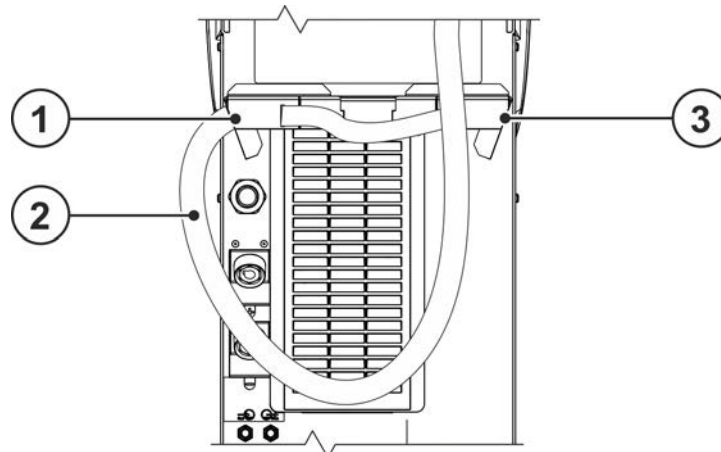

Figure 5-15

Item	Symbol	Description
1	DV1	Intermediate hose package strain relief For wire feeder 1
2		Intermediate hose package
3	DV2	Intermediate hose package strain relief For wire feeder 2

5.3.2.2 Locking the strain relief

EWM intermediate hose package

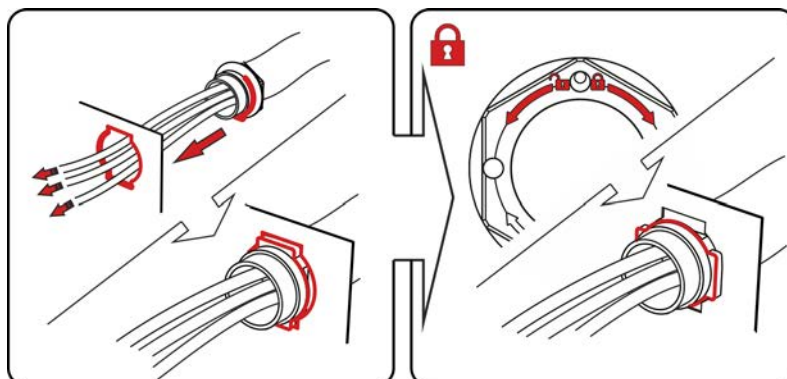

Figure 5-16

5.3.3 Connection for workpiece lead

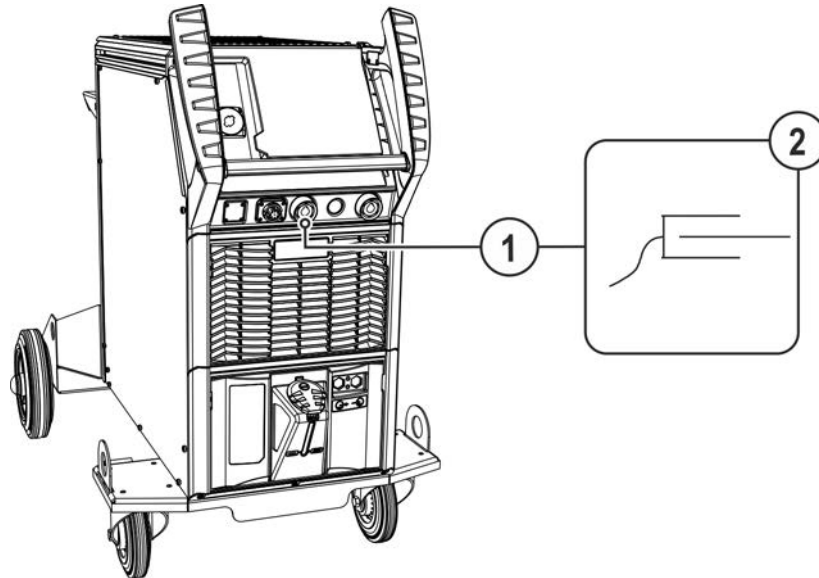



Figure 5-17

Item	Symbol	Description
1		Connection socket (+) welding current • TIG welding: Workpiece connection
2		Workpiece

- Insert the cable plug on the work piece lead into the "+" welding current connection socket and lock by turning to the right.

5.3.4 Welding task selection

For selection of the welding task and for general operation see the relevant Control operating instructions.

5.4 MMA welding

5.4.1 Connecting the electrode holder and workpiece lead

⚠ CAUTION



Risk of crushing and burns!

When changing stick electrodes there is a risk of crushing and burns!

- Wear appropriate and dry protective gloves.
- Use an insulated pair of tongs to remove the used stick electrode or to move welded workpieces.

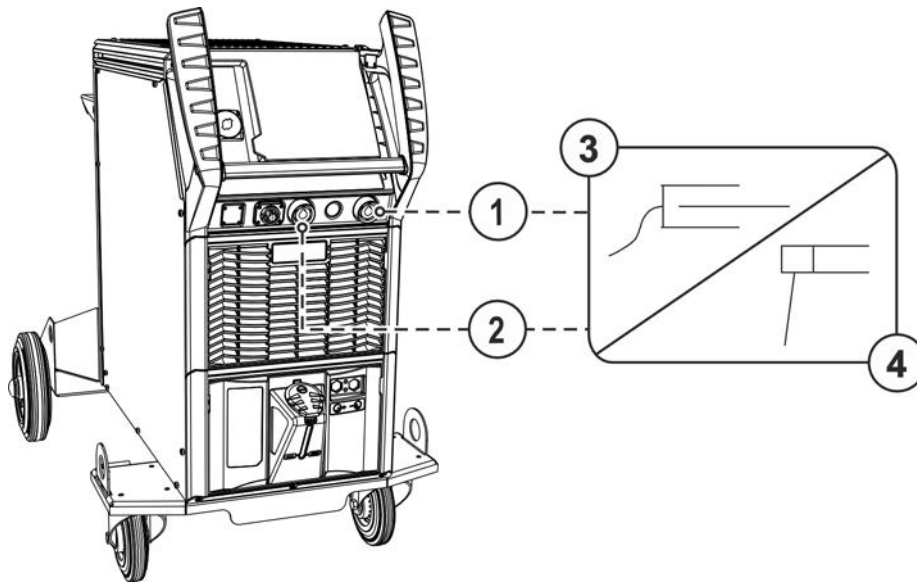

Figure 5-18

Item	Symbol	Description
1	—	Connection socket welding current (-)
2	+	Connection socket (+) welding current
3		Workpiece
4		Electrode holder

- Insert the electrode holder plug and workpiece lead into the welding current socket depending on application and lock in place by turning to the right. The corresponding polarity will be based on the information of the electrode manufacturer on the electrode packaging.

5.4.2 Welding task selection

For selection of the welding task and for general operation see the relevant Control operating instructions.

5.5 Remote control

The remote controls are operated on the 7-pole remote control connection socket (digital).

Read and observe the documentation to all system and accessory components!

5.6 Interfaces for automation

⚠ WARNING



No improper repairs and modifications!
 To prevent injuries and damage to the machine, only competent personnel (authorised service personnel) are allowed to repair or modify the machine.
 Unauthorised manipulations will invalidate the warranty!

- Instruct competent personnel (authorised service personnel) to repair the machine.



Unsuitable control cables or incorrect input/output signal assignment can cause damage to the machine. Use shielded control cables only.

5.6.1 Automation interface

⚠ WARNING



No function of the external interrupt equipment (emergency stop switch)!
 If the emergency stop circuit has been set up using an external interrupt equipment connected to the interface for automated welding, the machine must be configured for this setup. If this is not observed, the power source will ignore the external interrupt equipment and will not shut down!

- Remove jumper 1 on the corresponding control board (to be done only by qualified service personnel)!

These accessory components can be retrofitted as an option > see 9 chapter.

Pin	Input / Output	Name	Figure	
A	Output	PE ----- Connection for cable screen		
D	Output (open collector)	IGRO---- Current flows signal I>0 (maximum load 20 mA / 15 V) 0 V = welding current flows		
E/R	Input	Not-Aus- Emergency stop for higher level shut-down of the power source.		
F	Output	0V----- Reference potential		
G/P	Output	IGRO---- Current relay contact to the user, potential-free (max. +/-15 V / 100 mA)		
H	Output	Uist ----- Welding voltage measured against pin F, 0-10 V (0 V = 0 V; 10 V = 100 V) ^[1]		
L	Input	STA/STP Start = 15 V / Stop = 0 V ^[2]		
M	Output	+15 V---- Power supply (max. 75 mA)		
N	Output	-15 V ---- Power supply (max. 25 mA)		
S	Output	0 V----- Reference potential		
T	Output	list----- Welding current measured against pin F; 0-10 V (0 V = 0 A, 10 V = 1000 A) ^[3]		
				REGaus
				SYN_E
				IGRO
				Not/Aus
				0V
			IGRO	
			Uist	
			VSchweiss	
			SYN_A	
			STA/STP	
			+15V	
			-15V	
			IGRO	
			Not/Aus	
			0V	
			list	
			NC	
			NC	

^[1] Accuracy type ± (0.05 V+2.5 % of the measured value)

^[2] The operating mode is specified by the wire feeder (the start / stop function corresponds to the operation of the torch trigger and is used, for instance, in mechanized applications).

^[3] Accuracy type ± (0.02 V+2.5 % of the measured value)

5.6.2 RINT X12 robot interface

The standard digital interface for mechanised applications^{SEP}

Functions and signals:

- Digital inputs: start/stop, operating modes, JOB and program selection, inching, gas test
- Analogue inputs: control voltages, e.g. for welding performance, welding current, etc.
- Relay outputs: process signal, ready for welding, system composite fault, etc.

5.6.3 BUSINT X11 industrial bus interface

The solution for easy integration with automated production with e.g.

- Profinet/Profibus
- EnthernetIP/DeviceNet
- EtherCAT

etc.

5.7 PC interface

Welding parameter software

Set all welding parameters on the PC and simply transfer to one or more welding machines (accessory, set consisting of software, interface, connection leads)

- Data exchange between power source and PC
- Welding task administration (JOBS)
- Online-data exchange
- Specifications for weld monitoring
- Update function for new welding parameters

5.7.1 Connection



Equipment damage or faults may occur if the PC is connected incorrectly!

Not using the SECINT X10USB interface results in equipment damage or faults in signal transmission. The PC may be destroyed due to high frequency ignition pulses.

- **Interface SECINT X10USB must be connected between the PC and the welding machine!**
- **The connection must only be made using the cables supplied (do not use any additional extension cables)!**

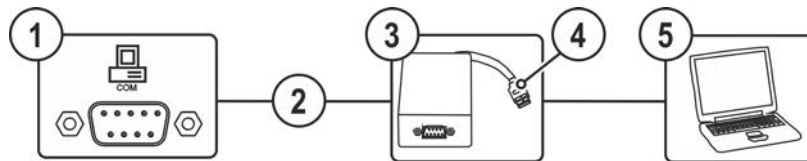

Figure 5-19

Item	Symbol	Description
1		Connection socket 9-pole - D-Sub PC interface
2		Connection cable 9-pole - serial
3		SECINT X10 USB
4		USB connection Connecting a Windows PC to SECINT X10 USB
5		Windows PC

5.8 Component identification

Only together with the device control Expert XQ 2.0 in the LAN gateway or LAN/Wi-Fi gateway version.

Bar codes predefined in ewm Xnet are recorded with a manual scanner. Component data are retrieved and displayed in the control.

These accessory components can be retrofitted as an option > see 9 chapter.

5.9 Network connection

This accessory component is only available as a “factory-fit option”.

The network connection allows the integration of the product into an existing network and exchanging data using the quality-management software Xnet. Some features of the software:

- Real-time display of the welding parameters
- Recording / documentation
- Monitoring of welding parameters
- Maintenance
- Calculations
- WPS management
- Welder management
- xButton management
- Component management

The functionality of the software is in constant development (see the documentation for Xnet).

As standard, welding machines are supplied with a fixed IP address.

Depending on the machine version, the IP address is displayed in the device control or shown on a sticker either below the rating plate or near the control.

The gateway and the server / computer must be in the same network or IP address range to allow the configuration of the gateway.

6 Maintenance, care and disposal

6.1 General

⚠ WARNING

Improper maintenance, testing and repairs!
Maintenance, testing and repair of the machine may only be carried out by skilled and qualified personnel (authorised service personnel). A competent person is someone who, based on training, knowledge and experience, can recognize the hazards and possible consequential damage that may occur when testing power sources and can take the necessary safety precautions.

- Follow the maintenance instructions > see 6.3 chapter.
- If any of the test requirements below are not met, the unit must not be put back into operation until it has been repaired and tested again.

As a rule, contact your specialised dealer, i.e. the supplier of the machine, with respect to all servicing matters. Any return deliveries in the case of warranty claims can be made via your specialised dealer only.

Only use original spare parts to replace any part. When ordering a spare part, always specify the type, serial number and article number of the machine, and the type designation and article number of the spare part.

Under the specified ambient conditions and normal working conditions this machine is essentially maintenance-free and requires just a minimum of care.

Contamination of the machine may impair service life and duty cycle. The cleaning intervals depend on the ambient conditions and the resulting contamination of the machine. The minimum interval is every six months.

6.2 Explanation of icons

Personnel

	Welder / operator		Qualified person (authorised service personnel)
--	-------------------	--	-------------------------------------------------

Test

	Visual inspection		Functional test
--	-------------------	--	-----------------

Period, interval

	One-shift operation		Multi-shift operation
	Every 8 hours		Daily
	Weekly		Monthly
	Every 6 months		Annually

6.3 Maintenance schedule

Inspector	Type of inspection	Period	Maintenance step	Repairer
		 	<p>! Only personnel designated as inspectors or repairers due to their training are allowed to carry out the relevant work step! Non-applicable inspection points are omitted.</p> <ul style="list-style-type: none"> • Check and clean the welding torch. Deposits in the welding torch may cause short circuits, impair the welding result and lead to welding torch damage! • Check wire drive, welding torches, and liner elements for application-related equipment and setting. 	

Inspector	Type of inspection	8h	24h	Maintenance step	Repairer
				<p>! Only personnel designated as inspectors or repairers due to their training are allowed to carry out the relevant work step! Non-applicable inspection points are omitted.</p>	
				<ul style="list-style-type: none"> • Clean the wire feed rolls on a regular basis (depending on the degree of soiling). Replace worn wire feed rolls. • Connections of the welding current leads (check for tight and locked seating). • Is shielding gas cylinder with gas cylinder securing elements (chain/belt) secured? • Strain relief: Are hose packages secured with strain relief? 	
				<ul style="list-style-type: none"> • Checking all supply lines and their connections (pipes, hoses, hose packages) for damage or leaks. • Checking the welding system for damage to the housing. • Transport elements (strap, lifting eyes, handle, wheels, parking brake) corresponding safety elements (if necessary fuse caps) are present and flawless? 	
				<ul style="list-style-type: none"> • Cleaning connections of coolant pipes (quick connect coupling, connections) from impurities and install protective caps when not in use. • Gas test that the solenoid valve opens and closes properly. • Checking operating, signalling and indicator lights, protective devices and actuators. 	
				<ul style="list-style-type: none"> • Check wire feed roll holder (wire feed rolls must be firmly seated on their holders and must not have any play) • Cleaning dirt filter (if applicable) > see 6.3.1 chapter 	
				<ul style="list-style-type: none"> • Checking correct mounting of the wire spool. 	
				<ul style="list-style-type: none"> • Clean external surfaces with a damp cloth (do not use aggressive cleaning agents). 	
				<ul style="list-style-type: none"> • Cleaning the power source (inverter) > see 6.3.4 chapter 	
				<ul style="list-style-type: none"> • Cleaning heat exchanger (torch cooling) > see 6.3.3 chapter 	
				<ul style="list-style-type: none"> • Coolant change (torch cooling) > see 6.3.2 chapter 	
				<ul style="list-style-type: none"> • Periodic inspection and testing > see 6.3.5 chapter 	
				<ul style="list-style-type: none"> • The coolant must be checked using the appropriate frost protection tester TYP 1 (KF) or FSP (blueCool) for sufficient frost protection and replaced if necessary (accessories). 	

6.3.1 Dirt filter

When using a dirt filter, the cooling air throughput is reduced and the duty cycle of the machine is reduced as a result. The duty cycle decreases with the increasing contamination of the filter. The dirt filter must be removed at regular intervals and cleaned by blowing out with compressed air (depending on the level of soiling).

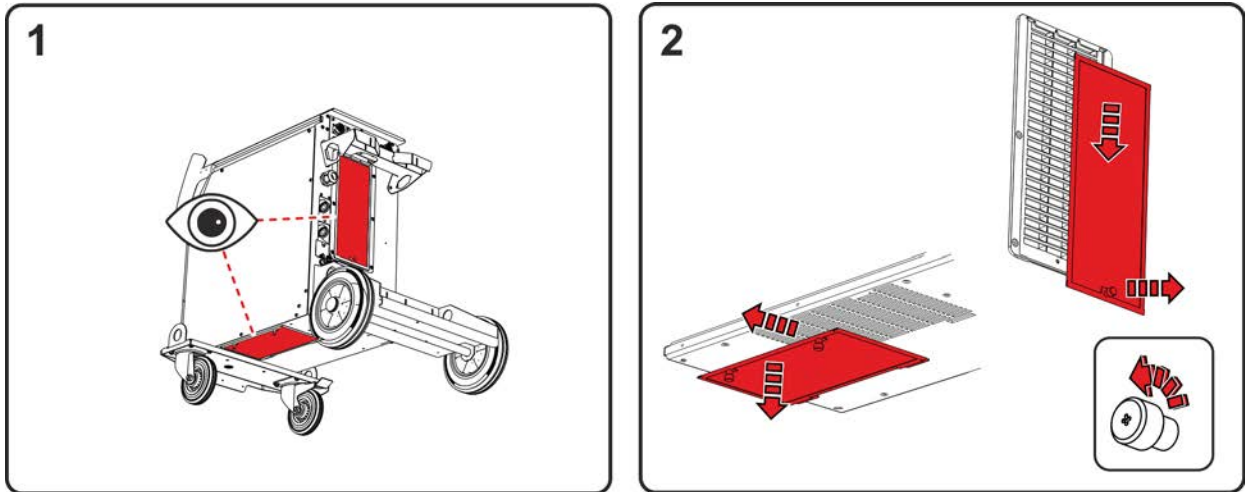

Figure 6-1

- Two dirt filters (option for retrofitting) can be installed on the machine. One at the air inlet of the power unit (inverter) and one at the air inlet of the heat exchanger (torch cooling).
- Loosen the locking screws of the filters (pull the filter of the power unit downwards and then backwards and the filter of the heat exchanger downwards and then to the side).

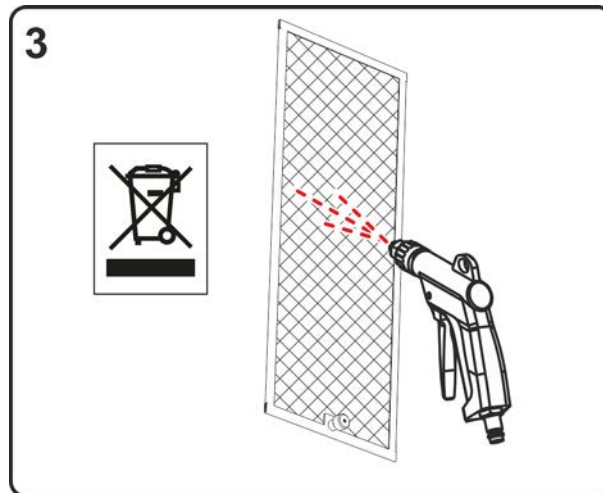

Figure 6-2

- Blow out the dirt filter with compressed air free of oil and water.

Follow official regulations on disposal!

- After cleaning, refit the filters in reverse order.

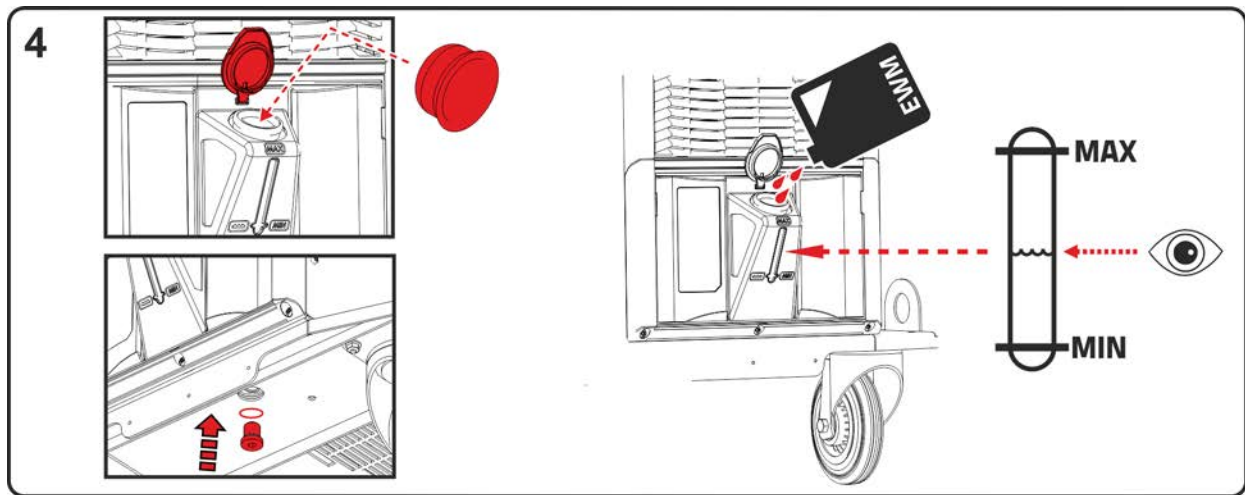

Figure 6-5

- Insert the cleaned filter screen into the filler neck and screw the drain plug with seal back into the tank.
- Fill the tank with original EWM coolant up to the maximum level. After filling, refit the tank cap and vent the coolant circuit > see 7.4 chapter.

6.3.3 Heat exchanger (torch cooling)

⚠ WARNING**Risk of injury due to insufficient training!****Appropriate training is required for the following maintenance steps to prevent injuries.**

- Only authorised service personnel may carry out this maintenance step.
- Note the warnings and maintenance instructions at the beginning of this chapter!

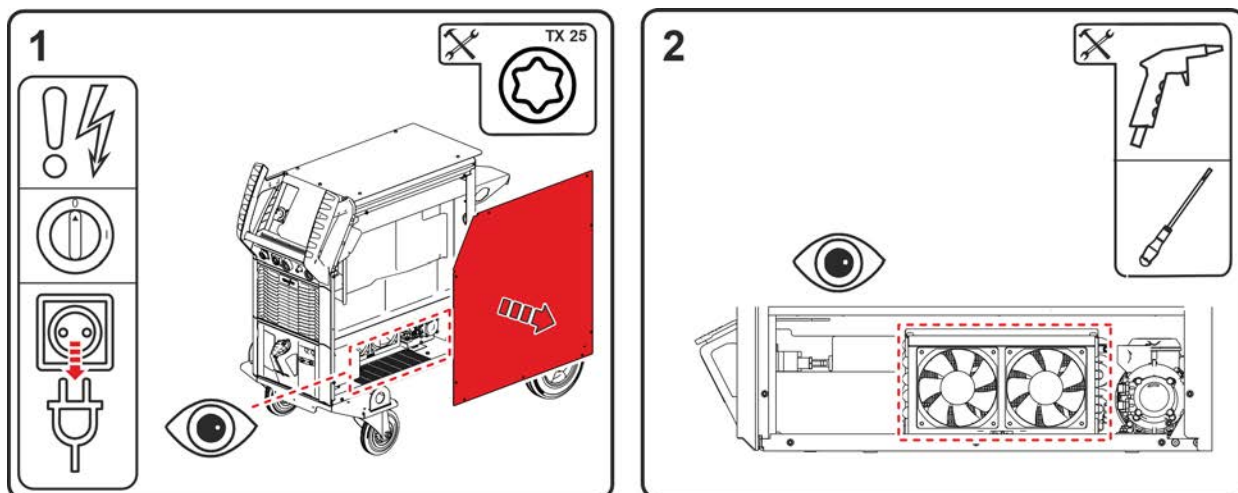

Figure 6-6

- Switch off the machine and disconnect the mains plug. Remove the screws of the side panel. Remove the side panel from the system (lift up and sideways).
- Use only compressed air free of water and oil. Do not blow on electronic components directly. The machine fans may over-rev due to the compressed air and thus become damaged. Therefore, use a screwdriver to block the machine fan mechanically. Please note: The strips of the heat exchanger behind the machine fans must not be damaged by the screwdriver.

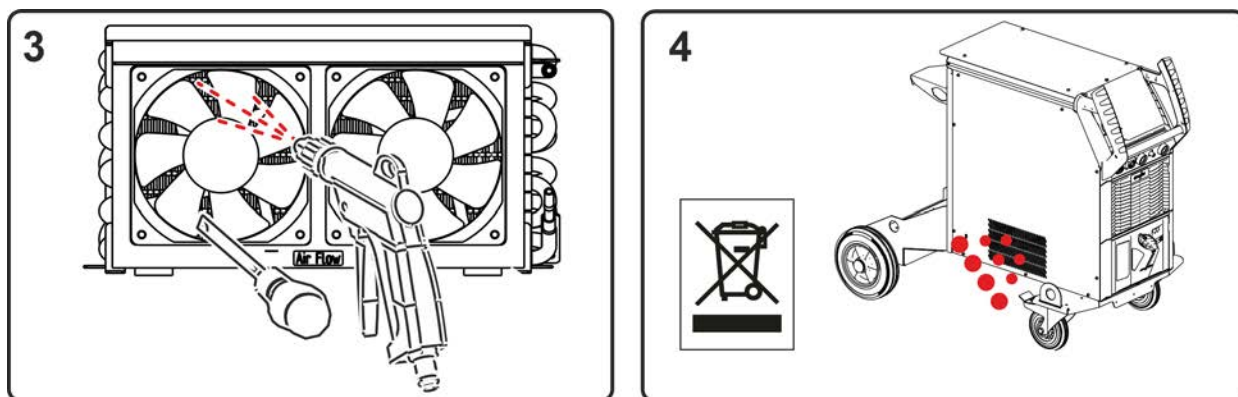

Figure 6-7

- Blow out the heat exchanger using the fans.
- The dirt escapes through the openings in the side panel.

Follow official regulations on disposal!

- After cleaning, remove any mechanical blockages from the fans, close the machine in reverse order and check according to applicable regulations.

6.3.4 Power source (inverter)

⚠ WARNING



Risk of injury due to insufficient training!

Appropriate training is required for the following maintenance steps to prevent injuries.

- Only authorised service personnel may carry out this maintenance step.
- Note the warnings and maintenance instructions at the beginning of this chapter!

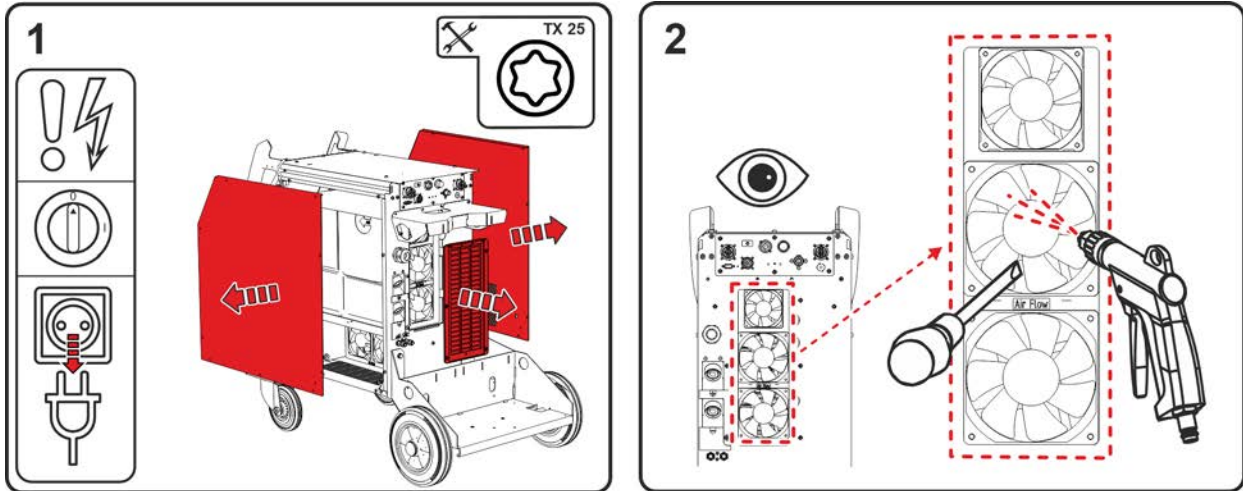

Figure 6-8

- Switch off the machine and disconnect the mains plug. Remove the screws of the side panels and the grille at the rear. Remove side panels (lift up and to the side). Remove louvre (remove downwards and to the back).
- Use only compressed air free of water and oil. Do not blow on electronic components directly. The machine fans may over-rev due to the compressed air and thus become damaged. Therefore, use a screwdriver to block the machine fan mechanically.

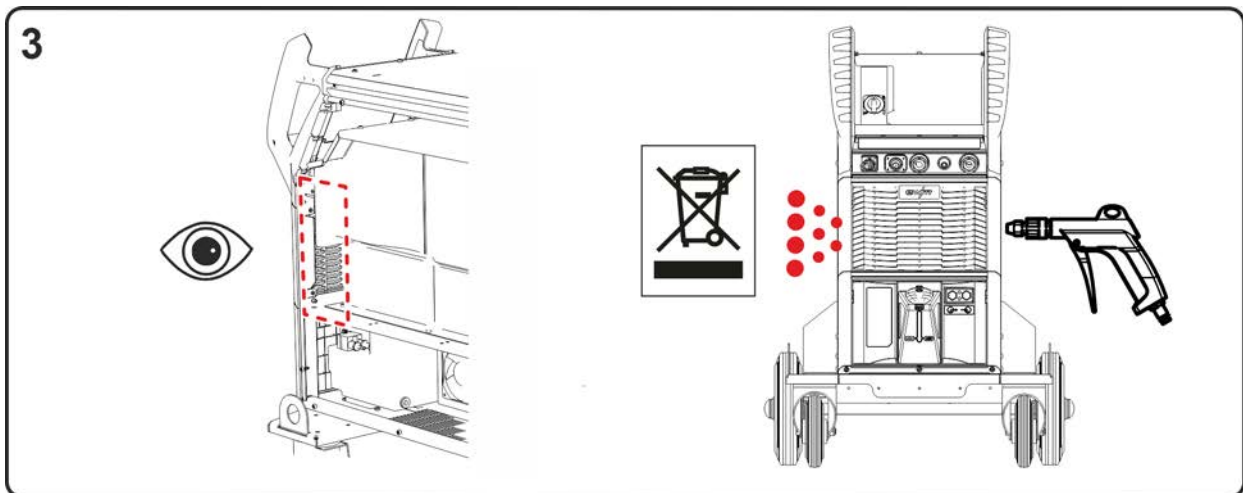

Figure 6-9

- Blow out the areas in front of the inverter from the side.

Follow official regulations on disposal!

- After cleaning, remove any mechanical blockages from the fans, close the machine in reverse order and check according to applicable regulations.

6.3.5 Annual test (inspection and testing during operation)

A periodic test according to IEC 60974-4 "Periodic inspection and test" has to be carried out. In addition to the regulations on testing given here, the relevant local laws and regulations must also be observed.

For more information refer to the "Warranty registration" brochure supplied and our information regarding warranty, maintenance and testing at www.ewm-group.com!

6.4 Disposing of equipment



Proper disposal!

The machine contains valuable raw materials, which should be recycled, and electronic components, which must be disposed of.

- Do not dispose of in household waste!
- Observe the local regulations regarding disposal!

In addition to the national or international regulations mentioned below, it is mandatory to follow the respective national laws and regulations on disposal.

- According to European provisions (Directive 2012/19/EU on Waste of Electrical and Electronic Equipment), used electric and electronic equipment may no longer be placed in unsorted municipal waste. It must be collected separately. The symbol depicting a waste container on wheels indicates that the equipment must be collected separately.

This machine has to be disposed of, or recycled, in accordance with the waste separation systems in use.

According to German law (law governing the distribution, taking back and environmentally correct disposal of electrical and electronic equipment (ElektroG)), used machines are to be placed in a collection system separate from unsorted municipal waste. The public waste management utilities (communities) have created collection points at which used equipment from private households can be disposed of free of charge.

The deletion of personal data is the responsibility of the end user.

Lamps, batteries or accumulators must be removed and disposed of separately before disposing of the device. The type of battery or accumulator and its composition is marked on the top (type CR2032 or SR44). The following EWM products may contain batteries or accumulators:

- Welding helmets
Batteries or accumulators are easy to remove from the LED cassette.
- Device controls
Batteries or accumulators are located on the back of these in corresponding sockets on the circuit board and are easy to remove. The controls can be removed using standard tools.

Information on returning used equipment or collections can be obtained from the respective municipal administration office. Devices can also be returned to EWM sales partners across Europe.

Further information on the topic of the disposal of electrical and electronic equipment can be found on our website at: <https://www.ewm-group.com/de/nachhaltigkeit.html>.



7 Rectifying faults

All products are subject to rigorous production checks and final checks. If, despite this, something fails to work at any time, please check the product using the following flowchart. If none of the fault rectification procedures described leads to the correct functioning of the product, please inform your authorised dealer.

7.1 Error messages (power source)

The possible error numbers displayed depend on the machine series and version!

Depending on the options of the machine display, a fault is shown as follows:

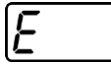
Display type - machine control	Display
Graphic display	
two 7-segment displays	
one 7-segment display	

The possible cause of the fault is signalled by a corresponding fault number (see table). In the case of an error, the power unit shuts down.

- Document machine errors and inform service staff as necessary.
- If multiple errors occur, these are displayed in succession.

Reset error (category legend)

^A The error message disappears when the error is eliminated.

^B The error message can be reset by pressing a push-button ◀.

All other error messages can only be reset by switching the machine off and on again.

Error 3: Tacho error

Categories A, B

- ✓ Fault in the wire feeder.
 - ✘ Check the electrical connections (connectors, lines).
- ✓ Permanent overload of the wire drive.
 - ✘ Do not lay the liner in tight radii.
 - ✘ Check the wire in the liner for ease of movement.

Error 4: Excess temperature

Category A

- ✓ The power source is overheating.
 - ✘ Allow the switched-on machine to cool.
- ✓ Fan is blocked, dirty or faulty.
 - ✘ Check the fan and clean or replace it.
- ✓ Air inlet or outlet is blocked.
 - ✘ Check the air inlet and outlet.

Error 5: Mains overvoltage

Category A ^[1]

- ✓ Mains voltage is too high.
 - ✘ Check the mains voltages and compare them with the connection voltages of the power source.

Error 6: Mains undervoltage

Category A ^[1]

- ✓ Mains voltage is too low.
 - ✘ Check the mains voltages and compare them with the connection voltages of the power source.

Error 7: Low coolant level

Category B

- ✓ Low flow rate.
 - ✘ Fill with coolant.
 - ✘ Check coolant flow - remove kinks in the hose package.
 - ✘ Adjust the flow threshold [2].
 - ✘ Clean the cooler.
- ✓ The pump does not turn.
 - ✘ Turn the pump shaft.
- ✓ Air in the coolant circuit.
 - ✘ Vent the coolant circuit.
- ✓ The hose package is not filled with coolant.
 - ✘ Switch the machine off and on > pump running > filling process.
- ✓ Operation with a gas-cooled welding torch.
 - ✘ Deactivate the torch cooling.
 - ✘ Connect the coolant feed and return with a hose bridge.

Error 8: Shielding gas error

Categories A, B

- ✓ No gas.
 - ✘ Check the gas supply.
- ✓ The pre-pressure is too low.
 - ✘ Remove kinks in the hose package (nominal value: 4-6 bar pre-pressure).

Error 9: Secondary overvoltage

- ✓ Overvoltage at the output: Inverter error.
 - ✘ Request service.

Error 10: Earth fault (PE error)

- ✓ Connection between welding wire and machine casing.
 - ✘ Remove the electrical connection.
- ✓ Connection between welding circuit and machine casing.
 - ✘ Check the connection and routing of the earth wire / welding torch.

Error 11: Fast shut-down

Categories A, B

- ✓ Remove the logical signal "Robot ready" during the process.
 - ✘ Eliminate errors in the higher-level control.

Error 16: Pilot arc power source - collective error

Category A

- ✓ The external emergency stop circuit has been interrupted.
 - ✘ Check the emergency stop circuit and eliminate the cause of the error.
- ✓ The emergency stop circuit of the power source has been activated (internally configurable).
 - ✘ Deactivate the emergency stop circuit.
- ✓ The power source is overheating.
 - ✘ Allow the switched-on machine to cool.
- ✓ Fan is blocked, dirty or faulty.
 - ✘ Check the fan and clean or replace it.
- ✓ Air inlet or outlet is blocked.
 - ✘ Check the air inlet and outlet.
- ✓ Short circuit on welding torch.
 - ✘ Check the welding torch.
 - ✘ Request service.

Error 17: Cold wire error

Category B

- ✓ Fault in the wire feeder.
 - ✘ Check the electrical connections (connectors, lines).
- ✓ Permanent overload of the wire drive.
 - ✘ Do not lay the liner in tight radii.
 - ✘ Check the liner for ease of movement.

Error 18: Plasma gas error

Category B

- ✓ No gas.
 - ✘ Check the gas supply.
- ✓ The pre-pressure is too low.
 - ✘ Remove kinks in the hose package (nominal value: 4-6 bar pre-pressure).

Error 19: Shielding gas error

Category B

- ✓ No gas.
 - ✘ Check the gas supply.
- ✓ The pre-pressure is too low.
 - ✘ Remove kinks in the hose package (nominal value: 4-6 bar pre-pressure).

Error 20: Low coolant level

Category B

- ✓ Low flow rate.
 - ✘ Fill with coolant.
 - ✘ Check coolant flow - remove kinks in the hose package.
 - ✘ Adjust the flow threshold [2].
 - ✘ Clean the cooler.
- ✓ The pump does not turn.
 - ✘ Turn the pump shaft.
- ✓ Air in the coolant circuit.
 - ✘ Vent the coolant circuit.
- ✓ The hose package is not filled with coolant.
 - ✘ Switch the machine off and on > pump running > filling process.
- ✓ Operation with a gas-cooled welding torch.
 - ✘ Deactivate the torch cooling.
 - ✘ Connect the coolant feed and return with a hose bridge.

Error 22: Excess coolant temperature

Category B

- ✓ Coolant is overheating [2].
 - ✘ Allow the switched-on machine to cool.
- ✓ Fan is blocked, dirty or faulty.
 - ✘ Check the fan and clean or replace it.
- ✓ Air inlet or outlet is blocked.
 - ✘ Check the air inlet and outlet.

Error 23: Excess temperature

Category A

- ✓ External component (e.g. HF ignition units) overheated.
- ✓ The power source is overheating.
 - ✘ Allow the switched-on machine to cool.
- ✓ Fan is blocked, dirty or faulty.
 - ✘ Check the fan and clean or replace it.
- ✓ Air inlet or outlet is blocked.
 - ✘ Check the air inlet and outlet.

Error 24: Pilot arc ignition error

Category B

- ✓ The pilot arc cannot ignite.
 - ✘ Check the welding torch equipment.

Error 25: Forming gas error

Category B

- ✓ No gas.
 - ✘ Check the gas supply.
- ✓ The pre-pressure is too low.
 - ✘ Remove kinks in the hose package (nominal value: 4-6 bar pre-pressure).

Error 26: Excess pilot arc module temperature

Category A

- ✓ The power source is overheating.
 - ✘ Allow the switched-on machine to cool.
- ✓ Fan is blocked, dirty or faulty.
 - ✘ Check the fan and clean or replace it.
- ✓ Air inlet or outlet is blocked.
 - ✘ Check the air inlet and outlet.

Error 32: Error I>0

- ✓ The current detection is incorrect.
 - ✘ Request service.

Error 33: Error UIST

- ✓ Voltage recording is faulty.
 - ✘ Eliminate the short circuit in the welding circuit.
 - ✘ Remove the external sensor voltage.
 - ✘ Request service.

Error 34: Electronics error

- ✓ A/D channel error
 - ✘ Switch the machine off and on.
 - ✘ Request service.

Error 35: Electronics error

- ✓ Slope error
 - ✘ Switch the machine off and on.
 - ✘ Request service.

Error 36: fault

- ✓  conditions violated.
 - ✘ Switch the machine off and on.
 - ✘ Request service.

Error 37: Excess temperature / electronics error

- ✓ The power source is overheating.
 - ✘ Allow the switched-on machine to cool.
- ✓ Fan is blocked, dirty or faulty.
 - ✘ Check the fan and clean or replace it.
- ✓ Air inlet or outlet is blocked.
 - ✘ Check the air inlet and outlet.

Error 38: Error IIST

- ✓ Short circuit in the welding circuit before welding.
 - ✘ Eliminate the short circuit in the welding circuit.
 - ✘ Request service.

Error 39: Electronics error

- ✓ Secondary overvoltage
 - ✘ Switch the machine off and on.
 - ✘ Request service.

Error 40: Electronics error

- ✓ Error I>0
- ✘ Request service.

Error 47: Radio link (BT)

Category B

- ✓ Connection error between the welding machine and peripheral unit.
- ✘ Note the documentation for the data interface with radio transmission.

Error 48: Ignition error

Category B

- ✓ No ignition at process start (automated machines).
- ✘ Check the wire feeding
- ✘ Check the load cable connections in the welding circuit.
- ✘ Clean corroded surfaces on the workpiece before welding if necessary.

Error 49: Arc interruption

Category B

- ✓ An arc interruption occurred during welding with an automated system.
- ✘ Check the wire feeding.
- ✘ Adjust the welding speed.

Error 50: Program number

Category B

- ✓ Internal error.
- ✘ Request service.

Error 51: Emergency stop

Category A

- ✓ The external emergency stop circuit has been interrupted.
- ✘ Check the emergency stop circuit and eliminate the cause of the error.
- ✓ The emergency stop circuit of the power source has been activated (internally configurable).
- ✘ Deactivate the emergency stop circuit.

Error 52: No wire feeder

- ✓ After switching on the automated system, no wire feeder (DV) was detected.
- ✘ Check or connect the control cables of the wire feeders.
- ✘ Check the identification number of the automated wire feeder (for 1DV: number 1, for 2DV: each a wire feeder with number 1 and a wire feeder with number 2).

Error 53: No wire feeder 2

Category B

- ✓ Wire feeder 2 was not detected.
- ✘ Check the control cable connections.

Error 54: VRD fault

- ✓ Error in the voltage reduction device.
- ✘ If necessary, disconnect the external machine from the welding circuit.
- ✘ Request service.

Error 55: Excess wire feeder current

Category B

- ✓ Excess current detected in the wire feed mechanism.
- ✘ Do not lay the liner in tight radii.
- ✘ Check the liner for ease of movement.

Error 56: Mains phase failure

- ✓ One phase of the mains voltage has failed.
 - ✘ Check the mains connection, mains plug and mains fuses.

Error 57: Slave tachometer error

Category B

- ✓ Fault in the wire feeder (slave drive).
 - ✘ Check the connections (connectors, lines).
- ✓ Permanent overload of the wire drive (slave drive).
 - ✘ Do not lay the liner in tight radii.
 - ✘ Check the liner for ease of movement.

Error 58: Short circuit

Category B

- ✓ Short circuit in the welding circuit.
 - ✘ Eliminate the short circuit in the welding circuit.
 - ✘ Place the welding torch on an insulated surface.

Error 59: Incompatible machine

- ✓ A machine connected to the system is not compatible.
 - ✘ Disconnect the incompatible machine from the system.

Error 60: Incompatible software

- ✓ The software of a machine is not compatible.
 - ✘ Disconnect the incompatible machine from the system
 - ✘ Request service.

Error 61: Welding monitoring

- ✓ The actual value of a welding parameter is outside the specified tolerance range.
 - ✘ Maintain the tolerance ranges.
 - ✘ Adjust the welding parameters.

Error 62: System component

- ✓ The system component was not found.
 - ✘ Request service.

Error 63: Mains voltage error

- ✓ Operating and mains voltage are incompatible.
 - ✘ Check or adjust the operating and mains voltage.

^[1] only Picotig 220 pulse

^[2] See technical data for values and other switching thresholds > see 8 chapter.

7.2 Warnings

Depending on the display options of the machine display, a warning message is displayed as follows:

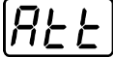
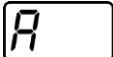
Display type - machine control	Display
Graphic display	
two 7-segment displays	
one 7-segment display	

The cause of the warning is indicated by a corresponding warning number (see table).

- In case of multiple warnings, these are displayed in sequence.
- Document machine warning and inform service personnel, if required.

Warning	Potential cause / remedy
1 Excess temperature	A shutdown is imminent due to excess temperature.
2 Half-wave failures	Check process parameters.
3 Welding torch cooling warning	Check the coolant level and top up if necessary.
4 Shielding gas	Check the shielding gas supply.
5 Coolant flow	Check min. flow rate. ^[2]
6 Wire reserve	Only a small amount of wire is left on the spool.
7 CAN bus failure	The wire feeder is not connected; the automatic circuit-breaker of the wire feed motor (reset the tripped automatic circuit breaker by actuating).
8 Welding circuit	The inductance of the welding circuit is too high for the selected welding task.
9 WF configuration	Check WF configuration.
10 Partial inverter	One of several partial inverters is not supplying welding current.
11 Excess temperature of the coolant ^[1]	Check temperature and switching thresholds. ^[2]
12 Welding monitoring	The actual value of a welding parameter is outside the specified tolerance range.
13 Contact error	The resistance in the welding circuit is too high. Check the earth connection.
14 Alignment error	Switch the machine off and on. If the error persists, notify Service.
15 Mains fuse	The power limit of the mains fuse is reached and the welding power is reduced. Check the fuse setting.
16 Shielding gas warning	Check the gas supply.
17 Plasma gas warning	Check the gas supply.
18 Forming gas warning	Check the gas supply.
19 Gas warning 4	reserved
20 Coolant temperature warning	Check the coolant level and top up if necessary.
21 Excess temperature 2	reserved
22 Excess temperature 3	reserved
23 Excess temperature 4	reserved

Warning	Potential cause / remedy
24 Coolant flow warning	Check the coolant supply. Check the coolant level and top up if necessary. Check flow and switching thresholds. [2]
25 Flow 2	reserved
26 Flow 3	reserved
27 Flow 4	reserved
28 Wire stock warning	Check the wire feeding.
29 Low wire 2	reserved
30 Low wire 3	reserved
31 Low wire 4	reserved
32 Tacho error	Fault of the wire feeder - permanent overload of the wire drive.
33 Wire feed motor excess current	Excess current detected on wire feed motor.
34 JOB unknown	JOB selection was not carried out because the JOB number is unknown.
35 Wire feed motor slave excess current	Excess current detected on wire feed motor slave (push/push system or intermediate drive).
36 Slave tacho error	Fault of the wire feeder - permanent overload of the wire drive (push/push system or intermediate drive).
37 FAST bus failure	The wire feeder is not connected (reset by actuating the automatic circuit breaker of the wire feed motor).
38 Incomplete component information	Check the Xnet component management.
39 Halfwave failure	Check supply voltage.
40 Weak power grid	Check supply voltage.
41 Cooling unit not recognised	A liquid-cooled welding torch was connected but no cooling unit has been detected. <ul style="list-style-type: none"> • Check the connection of the cooling unit • Use a gas-cooled welding torch
47 Battery (remote control, type BT)	Battery level is low (replace battery)

[1] only for the XQ machine series

[2] See technical data for values and other switching thresholds > see 8 chapter.

7.3 Checklist for rectifying faults

The correct machine equipment for the material and process gas in use is a fundamental requirement for perfect operation!

Legend	Symbol	Description
	↗	Fault/Cause
	✘	Remedy

Functional errors

- ✓ Mains fuse triggers - unsuitable mains fuse
 - ✘ Set up recommended mains fuse > see 8 chapter.
- ✓ Machine does not start up after switching on (device fan and possibly coolant pump have no function).
 - ✘ Connect the control cable of the wire feeder.
- ✓ All machine control signal lights are illuminated after switching on
- ✓ No machine control signal light is illuminated after switching on
- ✓ No welding power
 - ✘ Phase failure > check mains connection (fuses)
- ✓ Machine restarts continuously
- ✓ Wire feeder without function
- ✓ System does not start up
 - ✘ Make control lead connections and check that they are fitted correctly.
- ✓ Loose welding current connections
 - ✘ Tighten power connections on the torch and/or on the workpiece
 - ✘ Properly fasten the contact tip and contact tip holder.

Collective interference signal light illuminates

- ✓ Excess temperature, welding machine
 - ✘ Allow the machine to cool down whilst still switched on
- ✓ Welding current monitoring device triggered (stray welding currents flowing across the protective earth). The error must be reset by switching the machine off and on again.
 - ✘ Welding wire is touching electrically conductive casing parts (check wire guide, has the welding wire sprung off the wire spool?).
 - ✘ Check for a correct mounting of the welding lead. Fit the feeder clamp of the welding lead as close as possible to the arc.

Excess temperature signal light illuminates

- ✓ Excess temperature, welding machine
 - ✘ Allow the machine to cool down whilst still switched on

Coolant error/no coolant flowing

- ✓ Insufficient coolant flow
 - ✘ Check coolant level and refill if necessary
- ✓ Air in the coolant circuit
 - ✘ Vent coolant circuit > see 7.4 chapter

Wire feed problems

- ✓ Wire feed roll holder is worn (wire feed rolls must be firmly seated on their holders and must not have any play)
 - ✘ Replace wire feed roll holder (092-002960-E0000)
- ✓ Contact tip blocked
 - ✘ Clean and, if necessary, replace.
- ✓ Setting the spool brake
 - ✘ Check settings and correct if necessary
- ✓ Setting pressure units
 - ✘ Check settings and correct if necessary
- ✓ Worn wire rolls
 - ✘ Check and replace if necessary
- ✓ Wire feed motor without supply voltage (automatic cutout triggered by overloading)
 - ✘ Reset triggered fuse (rear of the power source) by pressing the key button
- ✓ Kinked hose packages
 - ✘ Extend and lay out the torch hose package
- ✓ Wire guide core or spiral is dirty or worn
 - ✘ Clean core or spiral; replace kinked or worn cores

7.4 Vent coolant circuit

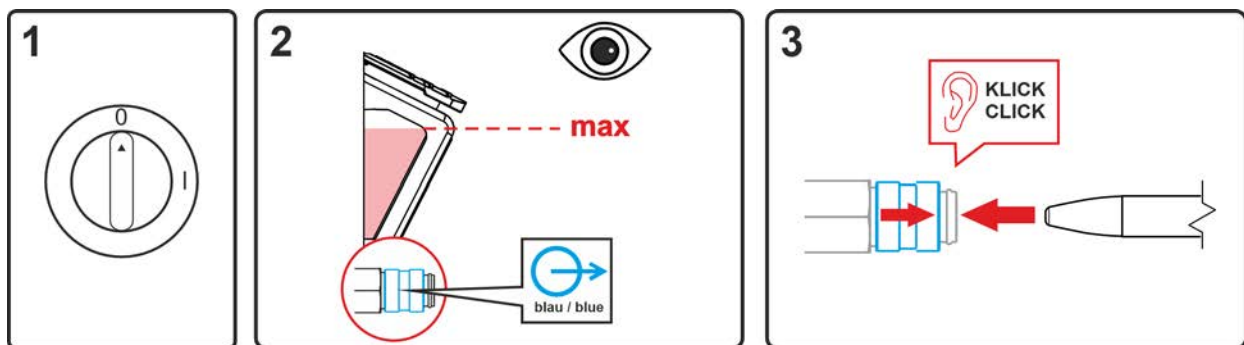

Figure 7-1

- Switch off the machine and fill the coolant tank to the maximum level.
- Unlock the quick-connect coupling with a suitable tool (connection open).

To vent the cooling system always use the blue coolant connection, which is located as deep as possible inside the system (close to the coolant tank)!

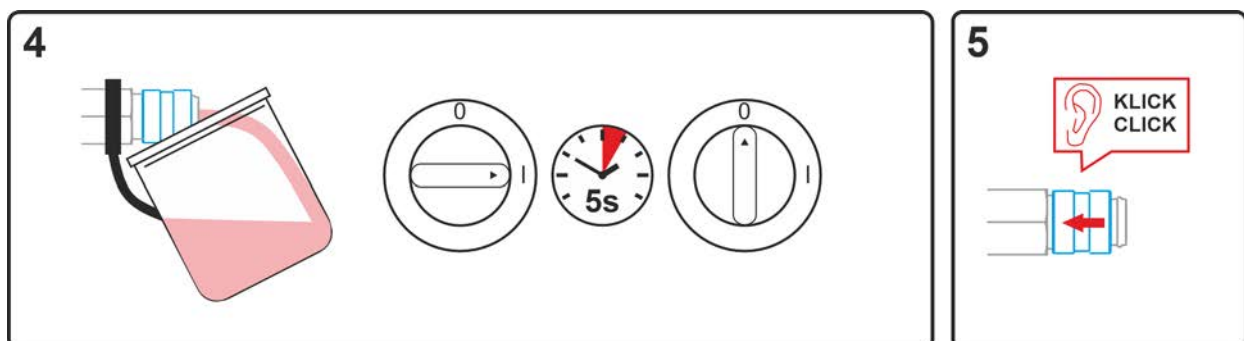

Figure 7-2

- Position a suitable collection container for collecting the escaping coolant at the quick-connect coupling and switch on the machine for approx. 5s.
- Lock the quick-connect coupling by pushing back the locking ring.

7.5 Fixing the pump shaft (coolant circuit)

Continuing non-use and impurities in the coolant may result in the the coolant pump not being in proper working order.

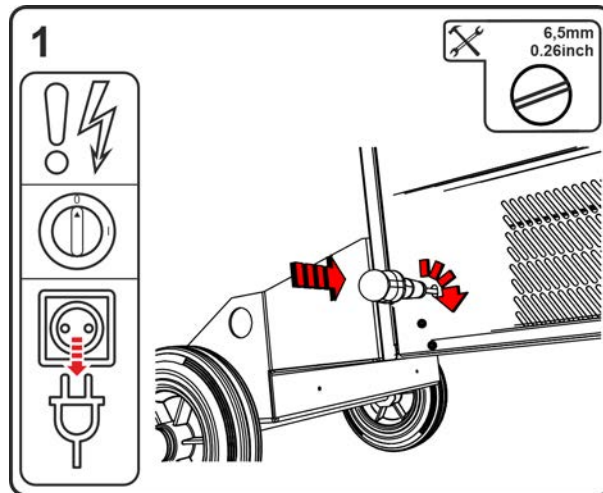

Figure 7-3

- Switch off machine at the main switch.
- Disconnect mains plug.
- Insert a plain slot screwdriver with a maximum tip width of 6.5 mm through the maintenance opening and place in the centre of the pump shaft. Turn the screwdriver clockwise until the pump shaft can be easily rotated again.
- Remove screwdriver.
- Insert mains plug of the switched-off machine into the appropriate socket.
- Switch on the power source at the main switch.

8 Technical data

8.1 Titan XQ 400 AC puls D

Performance specifications and guarantee only in connection with original spare and replacement parts!

8.1.1 Dimensions and weighte

	F06R1/R2		F06RS		F06P	
Dimensions (l x b x h)	mm	inch	mm	inch	mm	inch
l	1152	45.3	854	33.6	854	33.6
b	686	27.0	590	23.2	400	15.7
h	976	38.4	976	38.4	881	34.7
Weight ^[1]	kg	lb	kg	lb	kg	lb
F06W	128,5	283.2	118,3	260.8	103,3	227,7
F06WRF	132,5	292.1	122,3	269,6	107,3	236.5

^[1] All weight information refers to machine versions with 5 m (16.4 ft) mains connection cables. For versions with longer mains connection cables, the weight increases.

10 m (32.8 ft) = +2.5 kg (5.5 lb)





15 m (49.2 ft) = +5.0 kg (11.0 lb)

8.1.2 Welding torch cooling system

Torch cooling	F06W	F06WRF
Cooling capacity at 1 l/min (+25°C/77°F)	1,5 kW	
max. Flow rate	5 l/min 1.3 gal/min	20 l/min 5.2 gal/min
max. Delivery height	35 m 115 ft	45 m 148 ft
max. Pump pressure	3,5 bar 0.35 MPa	4,5 bar 0.45 MPa
Pump	Centrifugal pump	
max. Tank content	8 l 2.1 gal	
Flow monitoring Error limit Warning limit ^[1]	0,7 l/min / 0.18 gal/min Offset +0,3 l/min / Offset +0.08 gal/min	
Temperature monitoring Error limit Warning limit ^[1]	70°C / 158°F Offset -5°C / Offset -9°F	

^[1] Offset from the set error limit

8.1.3 Performance data

	MIG/MAG	MMA	TIG
Welding current (I_2)	5 A to 400 A		
Welding voltage according to standard (U_2)	14,3 V to 34,0 V	20,2 V to 36,0 V	10,2 V to 26,0 V
Duty cycle DC at 40° C ^[1]	400 A (80 %)		
	370 A (100 %)		
Mains voltage ^[2] / Frequency / Tolerance	380-400 V / 50/60 Hz / -25 % to +20 %		
	440-460 V / 50/60 Hz / -25 % to +15 %		
	480-500 V / 50/60 Hz / -25 % to +10 %		
mains fuse ^[3] (380-400 V)	3 x 25 A	3 x 25 A	3 x 20 A
mains fuse ^[3] (440-460 V)	3 x 25 A	3 x 25 A	3 x 20 A
mains fuse ^[3] (480-500 V)	3 x 20 A	3 x 20 A	3 x 20 A
Open circuit voltage U_0 (380-400 V)	82 V		
Open circuit voltage U_0 (440-460 V)	94 V		
Open circuit voltage U_0 (480-500 V)	102 V		
Mains connection cable	H07RN-F4G6		
max. Connected load S_1 water cooled	17,9 kVA	18,6 kVA	13,8 kVA
max. Connected load S_1 water cooled, Reinforced	18,2 kVA		14,0 kVA
Recommended generator power	24,6 kVA	25,1 kVA	19 kVA
Power consumption P_1 ^[4]	28 W		
Maximum mains impedance (@PCC)	120 mOhm		
Cos ϕ / efficiency	0,99 / 88 %		
Protection class / Overvoltage category	I / III		
Contamination level	3		
Insulation class / protection classification	H / IP 23		
Residual current circuit breaker	Type B (recommended)		
Noise level ^[5]	<70 dB(A)		
Ambient temperature ^[6]	-25 °C to +40 °C		
Machine cooling / Torch cooling	Fan (AF) / gas or water		
Workpiece lead (min.)	70 mm ²		
EMC class	A		
Test mark	 /  /  / 		
Standards used	See declaration of conformity (appliance documents)		

^[1] Load cycle: 10 min. (60 % DC \triangleq 6 min. welding, 4 min. pause) AC power sources: 50 Hz - waveform = square.

^[2] Factory-set mains voltage (cannot be configured later)

^[3] Safety fuses are recommended DIAZED xxA gG. When using automatic cutouts, the "C" trigger characteristic must be used.

^[4] Power in idle state without external or internal peripherals.

^[5] Noise level during idle mode and operation under standard load according to IEC 60974-1 at the maximum operating point.

^[6] Ambient temperature dependent on coolant! Observe coolant temperature range!

9 Accessories

Performance-dependent accessories like torches, workpiece leads, electrode holders or intermediate hose packages are available from your authorised dealer.

9.1 System components

9.1.1 Wire feed unit

Type	Designation	Item no.
Drive XQ LP	Drive XQ wire feeder	090-005570-00001
Drive XQ HP	Drive XQ wire feeder	090-005570-00002
Drive XQ EX	Drive XQ wire feeder	090-005570-00003

9.2 Welding torch cooling system

Type	Designation	Item no.
HOSE BRIDGE UNI	Tube bridge	092-007843-00000
LFMG HANNA DIST 3	Conductivity meter	094-026184-00000

9.2.1 Coolant - type blueCool

Type	Designation	Item no.
blueCool -10 5 l	Coolant up to -10 °C (14 °F), 5 l	094-024141-00005
blueCool -10 25 l	Coolant up to -10 °C (14 °F), 25 l	094-024141-00025
blueCool -30 5 l	Coolant up to -30 °C (22 °F), 5 l	094-024142-00005
blueCool -30 25 l	Coolant up to -30 °C (22 °F), 25 l	094-024142-00025
FSP blueCool	Frost protection tester	094-026477-00000

9.3 7-pole remote control

Type	Designation	Item no.
RC XQ Expert 2.0 2 m	Expert XQ 2.0 remote control	090-008824-00002
RC XQ Expert 2.0 5 m	Expert XQ 2.0 remote control	090-008824-00005
RC XQ Expert 2.0 10 m	Expert XQ 2.0 remote control	090-008824-00010
RC XQ Expert 2.0 15 m	Expert XQ 2.0 remote control	090-008824-00015

9.4 Option for retrofitting

Type	Designation	Item no.
ON PDM F.06/FS.01/TG.04 Expert-XQ 2.0 / Expert 2.0	Transparent protective screen for device control and remote control	092-004050-00000
ON CC F.06	Transparent cover cap for protection of control	092-004198-00000
ON HASE XQ	Support arm for the torch hose package	092-004314-00000
ON Partbox F.06	Box for storing wear parts and smaller accessories such as wire feed rolls for mounting on a flexFit housing system	092-004426-00000
ON PS F06 1D01	Pivot support for a wire feeder	092-003330-00000
ON PS F06 2D01	Transport support for two wire feeders	092-003331-00000
ON PS F06 1D02	Pivot support for an IC wire feeder	092-003332-00000
ON PS drive D.12	Pivot support (360°) for wire feeders	092-004184-00000
ON Shock Protect F06	Ram protection	092-003334-00000
ON Filter F06	Dirt filter for air inlet	092-003337-00000
ON HS F06	Holder for holding long hose packages and welding torch	092-003333-00000
ON CS F.06	Crane frame	092-003485-00000
ON TS F06 R	Torch holder, right	092-003335-00000
ON TS F06 L	Torch holder, left	092-003360-00000
ON SH F06 L	Scanner holder, left	092-003434-00000

9.5 Option for conversion

CAUTION



Risk of injury and equipment damage due to inadequate training!

The conversion options listed below generally involve opening the device. An opened machine poses various dangers (e.g., electrical voltages, hot coolant, etc.). Dangerous voltages can still be present in power sources even after they have been switched off.

- Only knowledgeable, qualified service personnel with appropriate training may carry out conversions.! Qualified people are those who, based on their training, knowledge and experience, can recognise the hazards and possible consequential damage that arise when testing welding power sources and take the necessary safety precautions. The unauthorised intervention will void the warranty.

Type	Designation	Item no.
OU F06WRF	Conversion kit, water block with reinforced pump	092-003493-00000
OU F06R1/R2	Conversion kit, single cylinder holder to double cylinder holder	092-003494-00000
OU 2DV	Conversion kit for two wire feeders	092-003497-00000
OU Expert XQ 2.0	Conversion kit, Expert XQ 2.0	092-003495-00000
OU Expert XQ 2.0 WLG	Conversion kit, Expert XQ 2.0 with LAN/Wi-Fi gateway including interface for barcode scanner	092-003496-00000
OU AIF F.06/TG.04	Conversion kit, 19-pole interface for automated welding	092-003498-00000
OU F06W	Conversion kit, water block	092-003492-00000

9.6 Shielding gas supply (shielding gas cylinder for welding machine)

Type	Designation	Item no.
Proreg Ar/CO2 230bar 15l D	Pressure regulator with manometer	394-008488-10015
Proreg Ar/CO2 230bar 30l D	Pressure regulator with manometer	394-008488-10030
DM 842 Ar/CO2 230bar 15l D	Pressure regulator with manometer	394-002910-00015
DM 842 Ar/CO2 230bar 30l D	Pressure regulator with manometer	394-002910-00030
GH 2X1/4" 2M	Gas hose	094-000010-00001
GH 2x1/4" 3m	Gas hose	094-000010-00003
GH 2X1/4" 5m	Gas hose	094-000010-00005
GH 2X1/4" 10 m	Gas hose	094-000010-00011
GH 2X1/4" 15m	Gas hose	094-000010-00015

9.7 General accessories

Type	Designation	Item no.
32A 5POLE/CEE	Machine plug	094-000207-00000

9.8 Computer communication

Type	Designation	Item no.
PC300 XQ Set	PC300.Net welding parameter software kit incl. cable and SECINT X10 USB interface	090-008777-00000

9.9 Networking / Xnet

Type	Designation	Item no.
Xnet LAN Gateway	LAN gateway in external casing	090-008833-00502
Xnet WiFi Gateway	WiFi gateway in external casing	090-008834-00502
Xnet Extended-Set LAN	Xnet retrofit set LAN: One machine licence, a LAN gateway and a network cable (10 m)	091-008833-00001
Xnet Extended-Set WiFi	Xnet retrofit set WiFi: One machine licence, one WiFi gateway, one 7-pole connection cable (5 m)	091-008834-00001

9.9.1 Connection cables



Type	Designation	Item no.
FRV 7POL 0.5 m	Extension/connecting cable	092-000201-00004
Splitter 2x 7POL	Distribution box to expand the existing 7-pole interfaces on the welding machine	090-008302-00000

9.9.2 Component identification

Type	Designation	Item no.
SCAN BC 8Pol	Barcode scanner	090-008823-00000

10 Appendix

10.1 Average wire electrode usage

5 m/min – 197 ipm								
	mm				inch			
	1.0	1.2	1.6		.040	.045	.060	
Steel	1.8	2.7	4.7	kg/h	3.9	5.9	10.3	lb/h
Stainless steel	1.9	2.8	4.8		4.1	6.1	10.5	
Aluminium	0.6	0.9	1.6		1.3	1.9	3.5	
10 m/min – 394 ipm								
Steel	3.7	5.3	9.5	kg/h	8.1	11.6	20.9	lb/h
Stainless steel	3.8	5.4	9.6		8.3	11.9	21.1	
Aluminium	1.3	1.8	3.2		2.8	3.9	7.0	

10.2 Average shielding gas usage

10.2.1 MIG/MAG welding

	mm	1.0	1.2	1.6	2.0
	inch	.040	.045	.060	.080
l/min		10	12	16	20
gal/min		2.64	3.17	4.22	5.28

10.2.2 TIG welding

	Gas nozzle number	4	5	6	7	8	10
	∅ mm	6.5	8.0	9.5	11	12.5	16
	∅ inch	0.26	0.31	0.37	0.43	0.5	0.63
l/min		6	8	10	12		15
gal/min		1.58	2.11	2.64	3.17		3.96

10.3 Searching for a dealer

Sales & service partners
www.ewm-group.com/en/specialist-dealers



"More than 400 EWM sales partners worldwide"