

PT-200PC Positioner is ProArc's solution for integration with leading cobot and robot brands, ensuring superior welding precision and efficiency.

Features

- Servo motor : Equipped with high-precision servo motors, offering stable speed control, enhancing welding quality and efficiency
- Large through hole reducer : Equipped with high-precision hollow reducers, with a repeatability of ≤ 0.5 arcmin and positioning accuracy of ≤ 2 arcmin
- Ethernet Modbus TCP communication interface

※ This model has no HMI.



• PT-200PC-100

Specification

Model	Unit	PT-200PC-62	PT-200PC-100
Power input		1Ø 220VAC 50/60Hz	
Capacity	kg	200	
Table dimension	mm	Ø300	
Rotation speed	rpm	0.02 ~ 30	
Through hole diameter	mm	Ø62	Ø100
Earthing	amp	300	
Tilt range	deg	0 ~ 90	
Dimension (A x B x C)	mm	465 x 315 x 365	
Center to floor (D)	mm	250	
Weight	kg	43	45

※ Specifications subject to change.

Dimensions

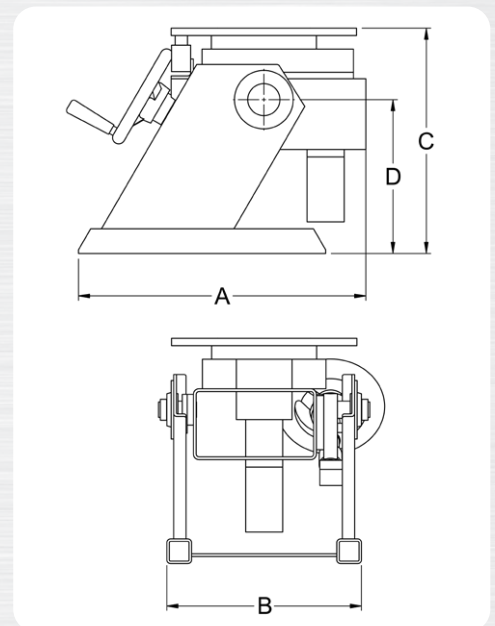

Options

- PG-300L 3-Jaw chuck
Self-centering, fast clamping and quick release
OD : 50 ~ 300 mm



• P/N : 0147-0010